



STUDY OF ENERGY EFFICIENT ELECTRONIC BALLAST

¹Anoop C P, ²Manjusha V A

Department of Electrical and Electronics

Amal Jyothi College of Engineering

Email- ¹anoopcp555@gmail.com, ²manjushava@amaljyothi.ac.in

Abstract- The demand of efficient lighting is increasing day by day. The efficient lighting includes maximum efficacy of light as well as maximum utilization of energy by improving the power factor with less complexity. The discharge lamps with high frequency electronic ballasts are used for maximum efficient lighting. The power factor of the ballast which is used in fluorescent lamp circuit should be increased in order to reduce the losses. Normally a self oscillating technique with two number of switches is used in electronic ballasts in fluorescent lamps. Along with the high frequency inverter, a converter based power factor corrector is used. Both the high frequency inverter part and the converter power factor corrector part are tried to integrate together in order to reduce the total number of switches and thereby reducing the control circuitry. The proposed topology is composed of a single-ended primary-inductance converter(SEPIC), used as a power-factor correction stage, integrated with a resonant half-bridge inverter. A single-stage HPF electronic ballast with two number of switches is designed for a 100 W fluorescent lamp operating at a frequency of 250 KHz and is simulated in Mat-lab SIMULINK software. This ballast is compared with self oscillating type of electronic ballast which is having no power factor correction stage.

Keywords – High power factor, high switching frequency, self-oscillating technique, converter power factor corrector, half bridge inverter, integration technique.

I. Introduction

Light is the prime factor in the human life as all activities of human life ultimately depend upon the light. Where there is no natural light, artificial light is used. Artificial lighting which can be produced electrically has cleanliness, ease of control, reliability, steady output, and low cost. It is playing an increasingly important part in modern everyday life. The efficient utilization of energy has been encouraged in recent years. More energy is wasted everyday because of the improper utilization of the available energy. More care is to be taken for the proper utilization of energy. The demand for efficient lighting is increasing day by day. Artificial lighting has an important responsibility on the consumption of overall generated electricity. The incandescent lamps have been replaced by discharge lamps due to its higher efficiency and longer lifetime when compared with the first one. The discharge lamps show better lighting performance since they are having high luminous efficacy. Among the discharge lamps, fluorescent lamps show good performance under low power applications. Like all gas discharge lamps, the fluorescent lamps need a ballast to prevent their destruction by excessive current because of their negative impedance.

High frequency operation of the ballast is preferable because it reduces the size of the components as well as better performance of the lamp is assured. Commercially self-oscillating technique is used because of its simplicity and ease of control. Due to high frequency switching, a distortion in input current waveform occurs and thereby reducing the power factor.

The main objective of the study is to design a new type of electronic ballast which is to be used in fluorescent lamps with high power factor, efficiency, efficacy and longer life. For this design a properly integrated operation of a converter and a half bridge inverter is taken[1]. A comparative study of the new topology with the other types of ballasts with no active power factor correction is to be done experimentally.

The discharge lamps shows better lighting performance since they are having high luminous efficacy. The operation of lamp at high frequency reduces the size of the components used and reduces flickering and humming sound. But the increase in frequency causes input current distortions and thereby reduces power factor. As per the IEC 61000-3-2 regulation the harmonic content of the current drained from the line is limited and it is particularly stringent for powers above 25W[1]. The improvement of power factor increases the efficiency of the power system. The efficacy of the light and its life time should be also high. In most of the industries, companies, most of the institutions and residential loads the lighting loads are the major loads. So proper care is to be taken. The proper design of the new topology with less components actually reduces the size of the hardware setup. The minimization of the loss increases the efficiency of the system.

The discharge lamps consists of gas filled inside the tube which ionises first and start conducting. At that stage current is to be limited by the lamp ballast. As said before, a gas discharge lamp is a light source that generates light by creating an electrical discharge through ionized gas. Typically, these lamps use noble gases such as argon, neon, krypton and xenon, or a mixture of these gasses. Many lamps are also filled with additional gases like sodium and mercury, while some others have metal halide additives. When power is applied to the lamp, an electrical field is generated in the tube. This field accelerates free electrons in the ionized gas. The electrons collide with the gas and metal atoms. Some electrons orbiting around these atoms are excited by the collision to a higher energy state. When the electron of the excited atom returns to its previous energy state, it releases energy in the form of photon. This light can be anything between IR, visible or UV radiation[2]. Some lamps have a fluorescent coating on the inside of the lamp to convert the

UV radiation into visible light. Some tubes contain some source of beta radiation to start ionization of the gas inside. in these tubes, glow discharge around the cathode is minimized, in favor of a so called positive column, filling the tube. Neon lamps is one good example.

II. PROPOSED TOPOLOGY

A. Single-stage SEPIC Half-bridge Integrated Electronic Ballast–

The circuit diagram of the new topology which is proposed here for PFC is shown in Fig. 1. Both the power factor correction stage and half bridge inverter stages are integrated.

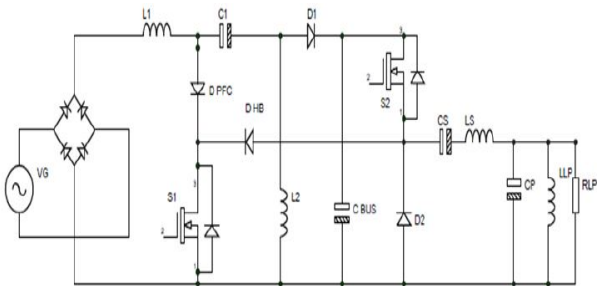

Figure 1. Proposed Single-Stage SEPIC Half-Bridge Integrated electronic Ballast

Here a SEPIC power factor corrector stage and lamp power control stage is used. The modes of converter operation is to be analyzed mathematically and the voltage and current equations are to be derived and then used to generate graphs of converter characteristics. The analysis and characteristics graphs are used as part of a design procedure to select the values of key converter parameters. In the next phase the computer simulation of the converter is to be performed on a simulation software. The Matlab SIMULINK simulation is used.

III. EXPERIMENT AND RESULT

The simulation is done for the new integrated topology in MATLAB software. The values of different parameters are given as per the design. The MATLAB Simulink diagram is shown in Fig. 2. The open loop simulation is done by giving the proper designed values. The input supply is 230 V and 50Hz and the switching frequency is 250 kHz. In the simulation the MOSFET switches and diodes considered are ideal and the other parameters of the power stage are same as design specification.

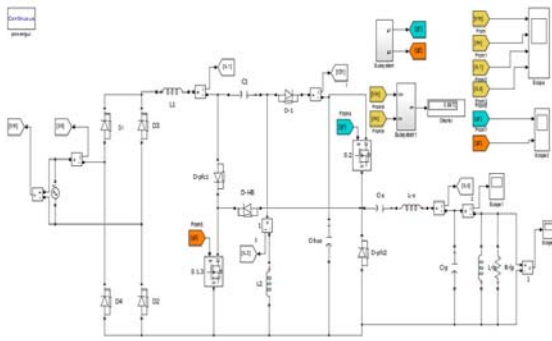

Figure 2. Output voltage waveform

The results obtained after performing the simulation is shown. All the waveforms obtained are studied well. The output voltage and current waveforms obtained are found to be as required for the rated operation of the lamp. The results are obtained for different time range.

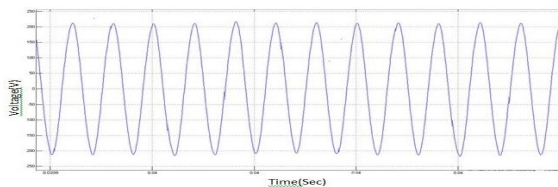

Figure 3. Output voltage waveform

The output voltage waveform is shown in Fig. 3. It shows a high frequency behavior. The lamp operates well in this voltage. Fig. 4 shows output current waveform.

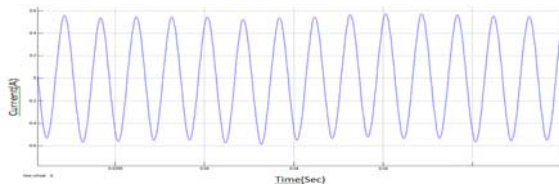

Figure 4. Output current waveform

Input voltage and current waveforms are shown in Fig. 5. Current waveform shows sinusoidal behavior.

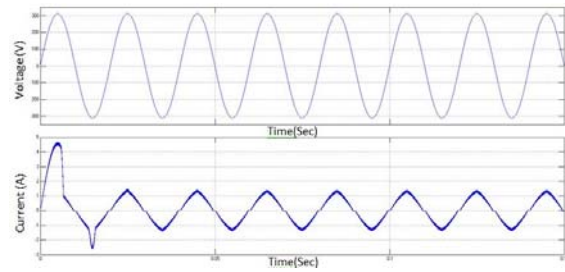

Figure 5. Input Current and Voltage Waveforms

The input current waveforms are clearly noted in order check the waveform distortions. The input current waveforms are found to be distorted in the first cycle operation but later in steady state the wave is found to follow the input sinusoidal voltage waveform.

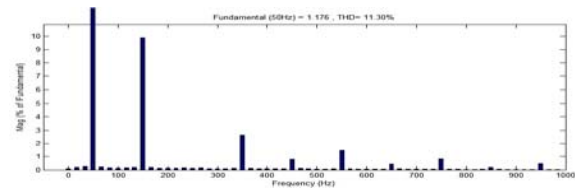

Figure 6. THD Measured in Input Current Waveform

The input voltage and current waveforms are found to be in phase and therefore the input displacement power factor measured is unity. The THD of the input current is measured to be 11.3 % which is shown in Fig. 6 and the input power factor measured is 0.98 . But there is some sort of distortion in the input current waveform due to the non-linearity by the high frequency switching. But the distortion in the waveform is reduced maximum due to the SEPIC converter operation in discontinuous mode. The design of the SEPIC converter integrated topology is such that it will act as a power factor pre-regulator

Hardware design of integrated topology is done on a PCB. PCB Layout is shown in Fig. 7

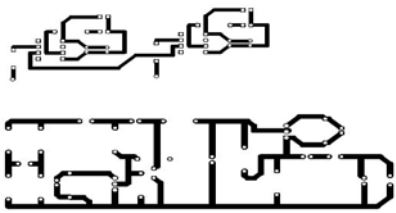

Figure 7. PCB Design done in Diptrace Software

The Pulse output from PIC microcontroller is shown in Fig. 8

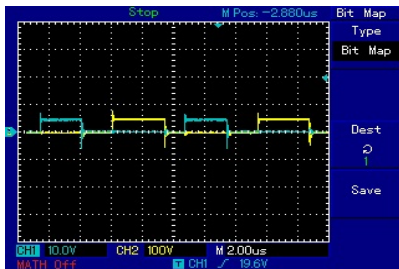

Figure 8. Pulse Output from PIC 16F877A

Complete hardware setup is shown in Fig. 9. Driver output is also shown in Fig 9.



Figure 9. Complete Hardware Setup

IV. CONCLUSION

High frequency electronic ballast using SEPIC integrated half bridge resonant inverter topology was developed. The system is designed for 100 watt output power. The frequency chosen for the high frequency electronic ballast is 250 KHz. In the case of self oscillating type of ballast, there is no power factor correction. A SEPIC power factor corrector is used in integrated topology. SEPIC converter can be operated as a power factor pre-regulator. The integration of the PFC and PC stages reduced the system component count. The simulation result shows input power factor of 0.98. The THD is reduced to 11.3%.

input current waveforms varies in the sinusoidal manner. This increased the efficiency of the system. This ensures better performance of the lamp.

V. REFERENCE

- [1] M.F da Silva, J. Fraytag, M.D Costa, J.M Alonso, R.N do Prado, "Analysis and design of a single-stage high-power-factor dimmable electronic ballast for electrodeless fluorescent lamp", *IEEE Transactions on Industrial Power electronics* 60(8), pp. 3081-3091, 2013
- [2] T.F Wu, T.H Yu, "Single stage electronic ballast with dimming feature and unit power factor" *IEEE Transactions on Power Electronics* 13(3), pp. 546-597, 1998.
- [3] T.F Wu, Y.K. Chen, "A systematic and unified approach to modeling PWM dc/dc converters based on the graft scheme", *Proceedings 22nd IEEE IECON*, Aug. 1996, 2, pp. 1041-1046
- [4] J.C. Hsieh and J. Lin, "Novel single-stage self-oscillating dimmable electronic ballast with high power factor correction", *IEEE Transactions on Industrial Electronics* 58(1), pp. 250-262, Jan. 2011
- [5] J.C.W Lam, P.K . Jain "A High-Power-Factor Single-Stage Single-Switch Electronic Ballast for Compact Fluorescent Lamps", *IEEE Transactions on Industrial Electronics*, 9(2), pp. 213-219 1994.
- [6] P.K Jain, J.C.W Lam, "A Novel High-Power-Factor Single-Switch Electronic Ballast," *Power Electronics, IEEE Transactions on Industrial Applications*", 46(6), pp. 2202-2211, 2010.
- [7] P. P. Amari, M. Akbari, A.H. Kashani, "Optimized Single-Stage Single-Switch Electronic Ballast for Compact Fluorescent Lamp", *International Conference on Power Electronics*, 58(8), pp. 3970-3980 2009.
- [8] D. Tollik, "Analysis and Design of a High-Power-Factor Single-Stage Buck-Boost Half-Bridge Electronic Ballast for Electrodeless Fluorescent Lamps", *International Conference on Power Electronics*, 1991, pp. 720-726