



# REPAIR AND REHABILITATION OF REINFORCED CONCRETE BEAMS

<sup>1</sup>P.Satheeshkumar, M.E, <sup>2</sup>K.Praveen Kumar, <sup>3</sup>A.Praveenraj, <sup>4</sup>S.Ranjith, <sup>5</sup>M.Tamilarasan

<sup>1</sup>Assistant Professor, Dept. Of Civil Engineering, Muthayammal Engineering College Rasipuram, Namakkal-637408

<sup>2,3,4,5</sup>Bachelor Of Engineering, Civil Engineering

Muthayammal Engineering College Rasipuram-637408

Anna University: Chennai 600 025

## ABSTRACT

To prevent disaster in future earthquakes, one way of repairing the members in reinforced concrete buildings is concrete jacketing. The present study investigates the effect of jacketing on the flexural strength and performance of beams. First, slant shear tests are conducted to study the interface between old and new concrete. Second, beam specimens are tested to study the effect of jacketing on the positive bending of the span region. Third, beam-column-joint sub-assembly specimens are tested to study the effect of jacketing on the positive bending of the beams adjacent to the joint. Further, analytical investigations are carried out to predict the experimental results. A layered approach is used for the prediction of the moment versus rotation curves for the retrofitted beam specimens. An incremental nonlinear analysis is adopted to predict the lateral load versus displacement behavior for the retrofitted sub-assembly specimens. Finally, guidelines are provided for the retrofitting of beams by concrete jacketing.

**Keywords:** Beam, Concrete Jacketing, Retrofit, Seismic Force, Seismic Damage, Retrofitting, Reinforced Concrete.

## 1.1. INTRODUCTION:

Structures deteriorate due to problems associated with reinforced concrete. Natural disasters like earthquakes have repeatedly demonstrated the susceptibility of existing structures to seismic effect and hence implements like retrofitting and rehabilitation of deteriorated structures are important in high seismic regions. Thus retrofitting and

strengthening of existing reinforced concrete structures has become one of the most important challenges in Civil engineering. Engineers often face problems associated with retrofitting and strength enhancement of existing structures. Commonly encountered engineering challenges such as increase in service loads, changes in use of the structure, design and/or construction errors, degradation problems, changes in design code regulations, and seismic retrofits are some of the causes that lead to the need for rehabilitation & retrofitting of existing structures. Complete replacement of an existing structure may not be a cost-effective solution and it is likely to become an increased financial burden if Upgrading is a viable alternative. In such occasions, repair and rehabilitation are most commonly used solutions. Reinforcement corrosion and structural deterioration in reinforced concrete (RC) structures are common and prompted many researchers to seek alternative materials and rehabilitation techniques. While many solutions have been investigated over the past decades, there is always a demand to search for use of new technologies and materials to upgrade the deficient structures. In this context, strengthening with Ferro cement composite materials in the form of external reinforcement is of great interest to the Civil engineering community. The conventional strengthening methods of reinforced concrete structures attempt to compensate the lost strength by adding more material around the existing sections. Thus retrofitting and rehabilitation of structures can be concluded to be the best alternative. Seismic retrofitting is the

modification of existing structures to make them more resistant to seismic activity, ground motion, or soil failure due to earthquakes. With better understanding of seismic demand on structures and with our recent experiences with large earthquakes near urban centers, the need of seismic retrofitting is well acknowledged. The main purpose of the retrofitting (strengthening) is to upgrade the resistance of damaged building while repairing so that it becomes safer under future earth quake occurrences.

This work may involve some of the following actions:

- a) Increasing the lateral strength in one or both directions by increasing column and wall areas or the number of walls and columns.
- b) Giving unity to the structure, by providing a proper connection between its resisting elements, in such a way that inertia forces generated by the vibration of the building can be transmitted to the members that have the ability to resist them.
- c) Eliminating features that are sources of weakness or that produce concentration of stresses in Some members.
- d) Avoiding the possibility of brittle modes of failure by proper reinforcement and connection of resisting members.

Externally bonded, FC sheets are currently being studied and applied around the world for the repair and strengthening of structural concrete members. FC composite materials are of great interest because of their superior properties such as high stiffness and strength as well as ease of installation when compared to other repair materials. Also, the non corrosive and non- magnetic nature of the materials along with its resistance to chemicals makes FC an excellent option for external reinforcement. The addition of externally bonded FC sheets to improve the flexural and shear performance of RC beams has been actively pursued during the recent years. Research reveals that strengthening using FC provides a substantial increase in post-cracking stiffness and ultimate

load carrying capacity of the members subjected to flexure and shear.

## **LITERATURE REVIEW**

The general advantages of concrete jacketing in the context of construction in India are as follows (Chakrabarti et al., 2008):

- Jacketing by concrete can increase both flexural and shear capacities of abeam.
  - The compatibility of deformation between the existing and new concrete, resistance against Delamination and durability are better as compared to a new material on a different substrate.
  - Availability of personnel skilled in concrete construction.
  - The analysis of retrofitted sections follows the principles of analysis of RC sections.
- Of course, there are certain disadvantages of concrete jacketing, depending on the structure and its use:
- Increase in the size and weight of the beam.
  - Anchoring of bars involves drilling of holes in the existing members.
  - Manufacturing of sufficiently workable concrete for the jacket.
  - Possibility of disruption to the users of the building.

Despite these disadvantages, concrete jacketing is a practical option for the buildings where beams are highly deficient in flexure or shear as compared to the required demands.

Liew and Cheong (1991) tested the simply supported beams retrofitted with jackets by using pre packed aggregate concrete. The additional reinforcement cage was attached by fixing the stirrups in the pre-located recesses. They concluded that the flexural strength can be

predicted by assuming full bond between the existing and new concrete.

The experiments conducted by Alcocer and Jirsa (1993) on beam-column-slab

Sub-assemblages showed that concrete jacketing is effective in strengthening frame members including the joint region. A steel cage was provided to confine the joint core, which was effective up to a storey drift of 4%. However, the retrofitting scheme involved substantial drilling of the existing concrete.

Bhedaogaonkar and Wadekar (1995) retrofitted beams by using the expanded wire Mesh reinforcement, while the supported slab was stiffened with an overlay. Cheong and MacAlevey (2000) conducted static and dynamic tests on 13 jacketed simply supported and continuous beams. The anchorage of bars was examined and negligible difference was noted, when the surface of the existing concrete was 'partially roughened' or 'fully roughened'.

Shehata et al. (2009) strengthened beams by attaching the additional reinforcement using expansion bolts as shear connectors. From the test results, it was concluded that this scheme is efficient in increasing the flexural strength and stiffness of the beams.

A 2D model was developed by Supaviriyakit et al. for analyses of RC beams strengthened with externally bonded Fc plates. The RC element considered the effect of crack and reinforcing steel as being smeared over the entire element. Perfect compatibility between cracked concrete and reinforcing steel was assumed. The FC plate was modeled as an elastic brittle element. As the epoxy is usually stronger than the concrete, perfect bond between FC and concrete was assumed.

The effect of anchorage length of near surface mounted reinforcement (NSMR) was studied by Lundqvist et al. They conducted numerical analyses of three different CFRP strengthening techniques to find a critical anchorage length, where a longer anchorage length does not contribute to the load bearing capacity. They

assumed perfect bond between the plate and concrete. The results showed that a critical anchorage length exists for plates and sheets as well as for NSMR.

Obaidat, Y.T., Dahlblom, O. and Heyden, S. has modeled a nonlinear 3-D numerical model has been developed using the ABAQUS finite element program, and it was used to examine the shear behavior of beams retrofitted by CFRP. Two models were used to represent the interface between CFRP and concrete, a perfect bond model and a cohesive model. Validation of the model was performed using data obtained from an experimental study. The results showed that the cohesive model is able to simulate the composite behavior of reinforced concrete beams retrofitted by CFRP in shear correctly. The model is then used to examine the influence of length and orientation of CFRP. It is shown that the length of CFRP and the orientation strongly influence on the behavior of the retrofitted beams.

Experimental data was obtained from previous research projects by Woo and Lee (2010), Mazzotti et al. (2008), Bizindavyi and Neale (1999), Dai et al. (2005), Pan and Leung (2007), Ming and Ansari (2004), Chajes et al. (1996) and from a literature review by Sharma et al. (2006) developed a total of eighteen prisms, strengthened with FRP, were selected for comparison with the numerical results. The prisms were connected to the machine through a steel frame with steel supports in order to prevent vertical and horizontal displacement. Strain gauges were mounted on the fiber reinforcement along the bonded length and load and corresponding strain along the FRP was measured. In most of the tests, the single lap pullout test method was used. In some specimens, Fig.4b, the FRP was not bonded to the concrete close to the edge. This was to avoid early failure due to concrete splitting caused by high transversal tensile stresses. In Ming et al. (2004), the double lap pull out test was used

Mrs. Tara Sen and Dr.H.N. Jagannatha Reddy (2011), had done a research on "Finite Element Simulation of Retrofitting of RCC Beam Using Coir Fibre Composite (Natural Fibre)"

**CONCLUSION OF LITERATURE:**

From the above reviews we referred we understand about the repair of the damaged beam and their strength parameters they have taken for their research. Retrofitting seems to be

**METHODOLOGY:**

a good development in the construction field and an effective method to strengthen the damaged beam.

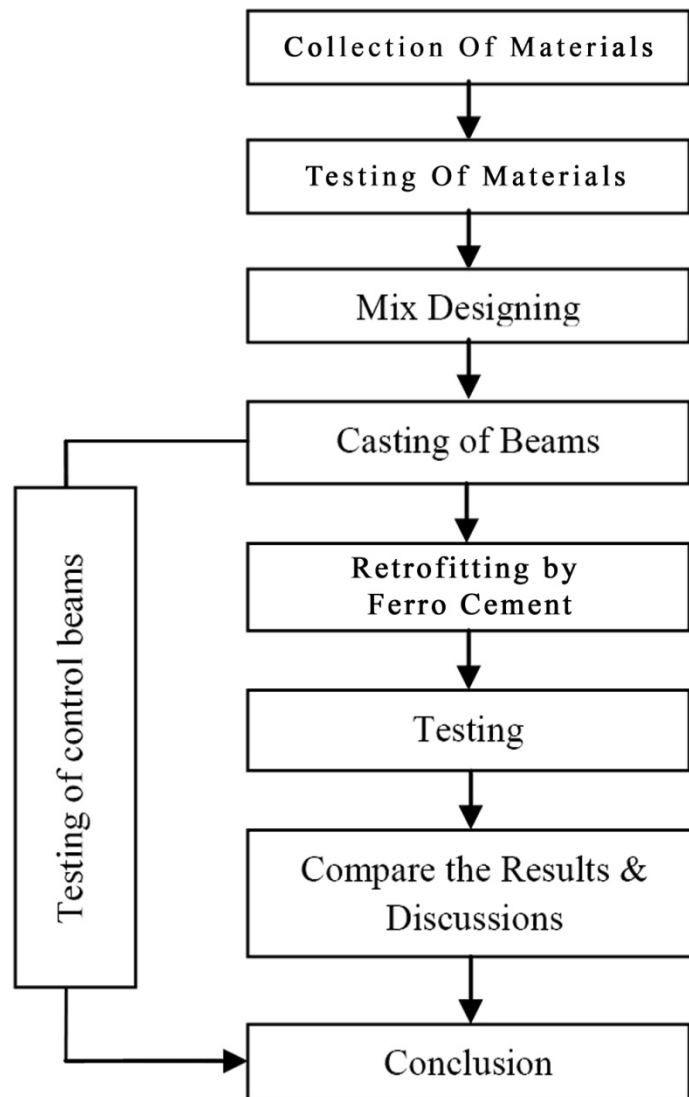
**MATERIALS:**

Ordinary Portland Cement of Grade 53 satisfying the requirements of IS 12269-1987 was used for the investigation. The initial setting time of cement was 30 minutes with a specific gravity of 3.15. It was tested for its physical properties as per Indian Standard specifications. The fine aggregate used in this investigation was clear river sand passing through 4.75 mm sieve with a specific gravity

of 2.604. The grading zone of aggregate was Zone III as per Indian Standard specifications. Machine crushed broken stone in angular shape was used as coarse aggregate. The maximum size of coarse aggregate was 20 mm and its specific gravity was 2.6. Ordinary clean potable water free from suspended particles and chemical substances was used for both mixing and curing of concrete. Design concrete mix of 1:1.25:2.72 by weight is used to achieve the

strength of 30 N/mm<sup>2</sup>. The water cement ratio of 0.45 was used. Three cube specimens were cast and tested (at the age of 28 days) to determine the compressive strength. The average compressive strength of the concrete was 36.87 N/mm<sup>2</sup>. HYSD bars of 12 mm diameter were used as longitudinal reinforcement and 8 mm diameter bars were used for shear reinforcement.

**1. Ordinary Portland Cement:**

Ordinary Portland Cement (OPC) the most widely and commonly used cement in the world. This type of cement is manufactured to powder by mixing limestone and other raw materials which consist of argillaceous, calcareous and gypsum. It is preferred in places where there is need of fast construction. This cement is available in the market in three grades namely OPC 33, OPC 43 and OPC 53. These grades imply the maximum strength of the particular cement after 28 days.

**2. Fly ash:**

- Ash produced in small dark flecks by the burning of powdered coal or other materials and carried into the air. Fly ash is very fine pozzolanic materials composed of ultrafine, amorphous glassy sphere of silicon dioxide.
- Fly ash is a byproduct from burning pulverized coal in electric power generating plants. As the fused material rises, it cools and solidifies into spherical glassy particles called fly ash.
- Fly ash is collected from the exhaust gases by electrostatic precipitators or bag filters
- The four most relevant characteristics of fly ash for use in concrete are loss on ignition (LOI), fineness, chemical composition and uniformity. LOI is a measurement of unburned carbon (coal) remaining in the ash and is a critical characteristic of fly ash, especially for concrete applications.
- Owing to its pozzolanic properties, fly ash is used as a replacement for Portland cement in concrete. As pozzolan greatly improves the strength and durability of concrete, the use of ash is a key factor in the preservation.
- The use of fly ash in Portland cement concrete (PCC) has many benefits and improves concrete performance in both the fresh and hardened state.

- Fly ash use in concrete improves the workability of plastic concrete, and the strength and durability of hardened concrete. Fly ash use is also cost effective.
- Fly Ash has very small particles which makes the concrete highly dense and reduces the permeability of concrete. It can add greater strength to the building. The concrete mixture generates a very low heat of hydration which prevents thermal cracking.

**3. Manufactured Sand (M-Sand):**

Manufactured sand (M-Sand) is a substitute of river sand for concrete construction. Manufactured sand is produced from hard granite stone by crushing.

The crushed sand is of cubical shape with grounded edges, washed and graded to as a construction material. The size of manufactured sand (M-Sand) is less than 4.75 mm.

Manufactured sand is an alternative for river sand. Due to fast growing construction industry, the demand for sand has increased tremendously, causing deficiency of suitable river sand in most part of the world.

Due to the depletion of good quality river sand for the use of construction, the use of manufactured sand has been increased. Another reason for use of M-Sand is its availability and transportation cost.

Since manufactured sand can be crushed from hard granite rocks, it can be readily available at the nearby place, reducing the cost of transportation from far-off river sand bed.

Thus, the cost of construction can be controlled by the use of manufactured sand as an alternative material for construction. The other advantage of using M-Sand is, it can be dust free, the sizes of m-sand can be controlled easily so that it meets the required grading for the given construction.

#### 4. HYSD BARS:

This helps in making the steel corrosion resistance and also increases its weld ability. On the other hand, HYSD stands for High Yielding Strength Deformed bars. These bars have more yield strength than Mild Steel. Unlike TMT bars, HYSD bars are both hot or cold worked. They are graded as Fe 415 or Fe500. HYSD stands for High Yielding Strength Deformed bars. These bars have more yield strength than Mild Steel. They are graded Fe415 & Fe500. HYSD bars have high carbon content because of that it is brittle.

#### CASTING OF BEAMS

The moulds were prepared using plywood. The dimensions of all the specimens were identical. The length of beams was 1000mm and the cross sectional dimensions were 150 mm x 150 mm. The design mix ratio was adopted for designing the beam. Thirty under reinforced beams were cast; five as control specimens and twenty five beams for retrofitting. Two bars of 12mm diameter were provided as tension reinforcement at the soffit of the beam and bars of 8 mm diameter were provided as shear reinforcement.

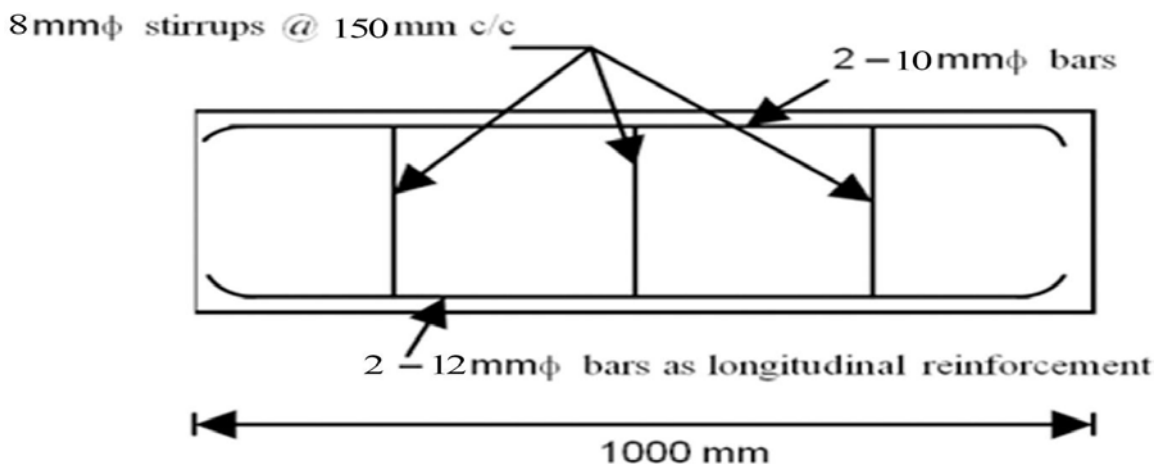

*Fig 1 Reinforcement detailing of the beam*

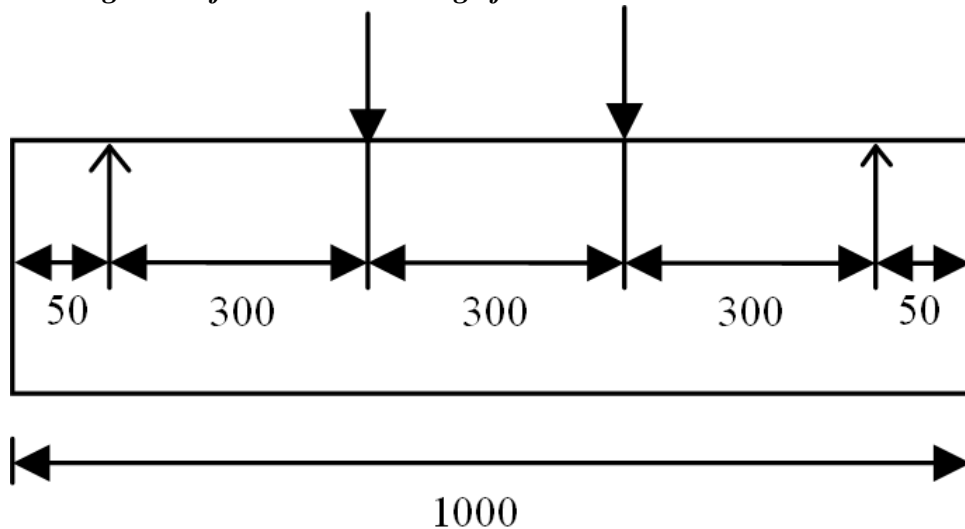

ALL DIMENSIONS IN mm

*Fig 2 Loading Diagram*

#### I. BATCHING:

##### Volume Batching:

- Volume batching is not a good method for proportioning the material because of the difficulty it offers to measure granular material in terms of volume.

- Volume of moist sand in a loose condition weighs much less than the same volume of dry compacted sand.
- The effect of bulking should be considered for moist fine aggregate.

- For unimportant concrete or for any small job, concrete may be batched by volume.

### Weigh Batching:

- Weigh batching is the correct method of measuring the materials.
- Use of weight system in batching, facilitates accuracy, flexibility and simplicity.
- Large weigh batching plants have automatic weighing equipment.
- On large work sites, the weigh bucket type of weighing equipment's are used.

## II. MIXING:

Thorough mixing of materials is essential for the production of uniform concrete. The mixing should ensure that the mass becomes homogeneous uniform in color and consistency. Types of mixing:

- ✓ Hand mixing
- ✓ Machine mixing

**Hand mixing** It is practiced for small scale unimportant concrete works. Hand mixing should be done over a impervious concrete or brick floor sufficiently large size take one bag of cement. Spread out and measure d out fine aggregates and coarse aggregate in alternative layers. Pour the cement on the top of it and mix them dry by shovel, turning the mixture over and over again until the uniformity of color is achieved. The uniform mixture is spread out in the thickness of about 20 cm. The water is taken and sprinkled over the mixture and simultaneously turned over. The operation is continued till such time a good uniform homogeneous concrete is obtained.



Machine mixing of concrete is almost invariably carried out by machine, for reinforced concrete work and for medium or large scale mass concrete work. Machine

mixing is not only efficient, but also economical, when the quantity of concrete to be produced is large. They can be classified as batch-mixers and continuous mixers. Batch mixers produce concrete, batch by batch with time interval, whereas continuous mixers produce concrete continuously without stoppage till such time the plant is working. In normal concrete work, it is the batch mixers that are used. Batch mixer may be of pan type or drum type. The drum type may be further classified as tilting, non-tilting, reversing or forced action type.

As per I.S. 1791–1985, concrete mixers are designated by a number representing its nominal mixed batch capacity in liters. The following are the standardized sizes of three types:

- Tilting: 85 T, 100 T, 140 T, 200 T
- Non-Tilting: 200 NT, 280 NT, 375 NT, 500 NT, 1000 NT
- Reversing: 200 R, 280 R, 375 R, 500 R and 1000 R



[a]machine batching

## TESTING OF ELEMENTS:

The full wrapping technique around all the four sides of the beam is used as the method of retrofitting. At the time of bonding of welded mesh, the concrete surface is made rough using a wire brush and then cleaned with water to remove all dirt and debris. The beams are allowed to dry for 24 hours. The welded mesh are cut according to their size. After that, the epoxy resin primer is mixed in accordance with manufacturer's instructions. The mixing is carried out in a plastic container (Base:

Hardener = 4Kg: 2 Kg). After uniform mixing, the epoxy resin primer is applied to the concrete surface. The beams are allowed to cure for 8 hours. The epoxy matrix is mixed in a plastic container in accordance with the manufacturer's instructions to produce a uniform mix of base and hardener (Base: Hardener = 3.7 : 1.3). The coating is applied on the beams and welded mesh mesh for effective bonding of the mesh with the concrete surface. Then the welded mesh is placed on top of epoxy resin coating and the resin is squeezed through the roving of the fabric. Air bubbles entrapped at the epoxy/concrete or epoxy/fabric interface are eliminated. During hardening of the epoxy, a pressure is applied on the composite fabric surface in order to extrude the excess epoxy resin and to ensure good contact between the epoxy, the concrete and the fabric. This operation is carried out at room temperature. Concrete beams strengthened with welded mesh are cured for 3 days at room temperature before testing.



Fig 3 compression test on cube

## RETROFITTING OF BEAMS

The full wrapping technique around all the four sides of the beam is used as the method of retrofitting. At the time of bonding of , the concrete surface is made rough using a wire brush and then cleaned with water to remove all dirt and debris. The beams are allowed to dry for 24 hours. The welded mesh are cut according to their size. After that, the epoxy resin primer is mixed in accordance with manufacturer's instructions. The mixing is carried out in a plastic container (Base: Hardener = 4Kg: 2 Kg). After uniform mixing, the epoxy resin primer is applied to the concrete surface. The beams are allowed to cure for 8 hours. The epoxy matrix is mixed in a plastic container in accordance with the manufacturer's instructions to produce a uniform mix of base and hardener (Base: Hardener = 3.7 : 1.3). The coating is applied on the beams and welded mesh for effective bonding of the mesh with the concrete surface. Then the welded mesh is placed on top of epoxy resin coating and the resin is squeezed through the roving of the fabric. Air bubbles entrapped at the epoxy/concrete or epoxy/fabric interface are eliminated. During hardening of the epoxy, a pressure is applied on the composite fabric surface in order to extrude the excess epoxy resin and to ensure good contact between the epoxy, the concrete and the fabric. This operation is carried out at room temperature. Concrete beams strengthened with welded mesh are cured for 3 days at room temperature before testing



Fig 4 Retrofitting of beams



## TESTING OF BEAMS

The control beams and the retrofitted beams were tested for the flexural strength. The testing procedure for the all the specimens was same. The beams were cured for a period of 28 days. The surface of control beams is cleaned and washed for clear visibility of cracks. The surface of the retrofitted beams is cleaned with cotton. The two-point loading arrangement is used for testing of beams. This has the advantage of a substantial region of nearly uniform moment coupled with very small shears, enabling the bending capacity of the central portion to be assessed. The load is transmitted through a load cell. The test beam was supported on roller bearings acting as supports. The specimen was placed over the two

steel rollers bearing leaving 50 mm from the ends of the beam. The remaining 900 mm was divided into three equal parts of 300 mm as shown in the fig 2. Two point loading arrangement was done as shown in the figure. Loading was done by hydraulic jack. Dial gauge was used for recording the deflection of the beams. The deflections of the beams were noted till the appearance of the first crack using dial gauge. The dial gauge was removed after the appearance of the crack and the load was further applied till fracture load. The ultimate loader fracture load was taken as the load at which the needle of load dial on the UTM returned back. The average of the five trials was taken and the load –deflection graph was plotted

*. Fig 5 Experimental test setup*



Six sets of beams were tested for their ultimate strengths. It is found that all the beams were failed in flexure. It is observed that the control beam had less load carrying capacity and high deflection values compared to that of the externally strengthened beams using FC mesh. The deflection of each beam for two point loading is analyzed. The deflections of each type of retrofitted beams are compared with the control beam. Also the load deflection behavior is compared between beams retrofitted with different FC mesh having the same reinforcement. It is noted that the behavior of the beams when bonded with FC mesh are better than the control beams. The deflections are lower when bonded externally with FC mesh. The use of FC mesh had effect in delaying the growth of crack formation.

When all the retrofitted beams are considered it is found that the beams with FC mesh wrapping had a better load deflection behavior compared to the other strengthened beams. It is found to be more effective in improving the flexural strength of the beam. At the load of 95 KN the first crack appeared on the beam. The external strengthening of beams using FC also reduced the deflections of the beams to an extent. But it had a less load deflection performance when compared with that of FC strengthened beams. The strengthening of beams using steel, coir and polypropylene welded mesh mesh also enhanced the resistance to deflection under applied load. FC retrofitted beams had a better load deflection behavior than the coir welded mesh and FC retrofitted beams.



**Fig 6 Cracks on control specimen**

Since the full wrapping technique is used for retrofitting, initial cracks are not visible. Further with increase in loading, propagation of the cracks took place but it had poor visibility of cracks due to the covering of the FC mesh. The

beams retrofitted with FC had the maximum deflections and lower ultimate load carrying capacity. From the graph it is clear that all the FC retrofitted beams have better load deflection characteristics than the control specimen



**Fig 7 Failure of Retrofitted beam**

Retrofitting of beams enhances the ultimate load capacity of the beams. The control specimen had an ultimate load of 63.3 KN, whereas all the retrofitted beams had an ultimate load greater than 80 KN. The ultimate load capacity of the FC retrofitted beams increased by 125% than the control specimen and had the highest ultimate load capacity than

all other retrofitted beams .FC retrofitted beams had an ultimate load of 120 KN, which 89.6% greater than that of control specimen. Among the five sets of retrofitted beams, the beams retrofitted with FC had the least ultimate load carrying capacity and the value is 86.74KN, which is 37.03% greater than the ultimate load capacity of control specimen

### **CONCRETE MIX DESIGN** **M30 GRADE CONCRETE** **OPC = 53 GRADE**

STEP: 1

Target mean strength

$$f_{ck} = f_{ck} + 1.65s$$

$$= 30 + 1.65(5.0) = 38.25 \text{ N/mm}^2$$

Water cement ratio 0.45% AS per IS 4586-2000

M30 grade concrete = 0.45% of water content

$$= 320\text{kg/m}^3 \text{ minimum cement content}$$

The water cement ratio of target mean strength of  $38.25\text{N/mm}^2$  is 0.45

STEP: 2

Selection of water and sand content

From table 2 of IS 10262:2009

20 mm maximum size aggregate sand conforming grading zone 3 water content Per cubic meter = 186kg/m<sup>3</sup>

Water content = +3% Sand content = - 3.5%

Water content = 191.6 liter/m<sup>3</sup>

Maximum cement content = 191.6/0.45 = 425.77kg/m<sup>3</sup>

STEP: 3

Determination of coarse and fine aggregate

| Maximum size aggregate ( mm ) | Entrapped air as % |
|-------------------------------|--------------------|
| 10                            | 3.0                |
| 20                            | 2.0                |
| 40                            | 1.0                |

Air content

20 mm aggregate = 2.0% air

Total aggregate volume = 35%

STEP: 4

$V = [ W + C/S + 1/P f_a/S_{fa} ] CA = 1-P$

$X f_a X S_{ca}/S_{fa}$

Where V = volume

[ 1-2/100] = 0.98%

W = mass of water [191.6 L/m<sup>3</sup>]

C = mass of cement [425.77 kg/m<sup>3</sup>]

S<sub>c</sub> = specific gravity of cement [ 3.1 ] P = ratio of fine aggregate

F<sub>a</sub> ,C<sub>a</sub> = total mass of fine aggregate coarse aggregate [ kg/m<sup>3</sup> ]

STEP: 5

Calculation

$V = [191.6 + 426/3.1 + 1/0.315 [ f_a/2.60 ] 0.98 = [329.01 + f_a x 1.22]$

$980 = [329.01 + 1.22 f_a ]$

$1.22 f_a = 980-329.01$

$1.22 f_a = 650.99$

$F_a = 533.59 \text{ kg/m}^3$   $C_a = 1-p/p \times f_a \times s_{ca}/s_{fa} = 1-0.315/0.315 \times 533.59 \times 2.6/2.6$

$C_a = 1160.34 \text{ kg/m}^3$

**DESIGN MIX FOR 1 M<sup>3</sup>**

| WATER      | CEMENT | FA       | CA        |
|------------|--------|----------|-----------|
| 191.6liter | 426kg  | 533.59kg | 1160.34kg |
| 0.46       | 1      | 1.25     | 2.72      |

NOMINAL MIX MORTAR CUBE

FOR 1 CUBE

Cube mould size =  $0.0706 \times 0.0706 \times 0.0706 \text{ m}^3$  Cube

mould volume =  $0.003518 \text{ m}^3$

Ratio = 1: 3

QUANTITIES

Cement =  $1/1+3 \times 0.0003518 \times 144 \times 1.33 = 0.1684 \text{ kg}$

Sand =  $0.1684 \times 3 = 0.5053 \text{ kg}$

Water cement ratio = 0.45  
Water content =  $0.45 \times 168.4 = 75.78 \text{ ml}$

ADMIXTURE MIX MORTAR CUBE

FLYASH FOR 1 CUBE

About 5% of fly ash

$5/100 \times 0.1684 = 0.00842 \text{ kg} = 8.42 \text{ gm}$

QUANTITIES

Cement = 0.15998 kg

Sand = 0.5053 kg

Water = 75.78ml

About 6% of fly ash  $6/100 \times 0.1684 = 0.00104 \text{ kg} = 10.104 \text{ gm}$

QUANTITIES

Cement = 0.158 kg

Sand = 0.5053 kg

Water = 75.78ml

About 7 % of fly ash  $7/100 \times 0.1684 = 0.01178 \text{ kg} = 11.788 \text{ gm}$

QUANTITIES

Cement = 0.156612 kg

Sand = 0.5053 kg

Water = 75.78ml

About 8% of fly ash  $8/100 \times 0.1684 = 0.013472 \text{ kg} = 13.471 \text{ gm}$

QUANTITIES

Cement = 0.154 kg

Sand = 0.5053 kg

Water = 75.78ml

About 9% of fly ash  $9/100 \times 0.1684 = 0.015156 \text{ kg} = 15.15 \text{ gm}$

QUANTITIES

Cement = 0.153 kg

Sand = 0.5053 kg

Water = 75.78ml

About 10% of fly ash  $10/100 \times 0.1684 = 0.01684 \text{ kg} = 16.84 \text{ gm}$

QUANTITIES

Cement = 0.151 kg

Sand = 0.5053 kg

Water = 75.78ml

DESIGN MIX FOR CONCRETE CUBE

M 30 GRADE CONCRETE FOR 1 CUBE

M 30 = 1 : 1.25 : 2.72 = 4.97

Mould size = 0.150 x 0.150 x 0.150m<sup>3</sup>

Volume = 0.003375m<sup>3</sup>

1/1+1.25+2.72 x 0.003375 x 14401 1.54

QUANTITIES

Cement = 1.505kg

Sand= 1.505 x 1.25 = 1.88125kg

Aggregate = 1.505 x 2.72 = 4.0936kg

Water ratio = 0.45 x 1505 = 677.25ml

DESIGN MIX FOR CONCRETE BEAMS

M 30 GRADE CONCRETE FOR 1 BEAM

M 30 = 1 : 1.25 : 2.72 = 4.97

Mould size = 1 x 0.15 x 0.15 m<sup>3</sup>

Volume = 0.0225 m<sup>3</sup>

M30 design mix ratio = 1 : 1.25 : 2.72

1/1+1.25+2.72 x 0.0225x 14401 1.54

QUANTITIES

Cement = 10.039 kg

Sand = 10.039 x 1.25 = 12.54 kg

Aggregate = 10.039 x 2.72 = 27.306 kg

Water ratio = 0.45 x 10.039 = 4.5 liter

**TESTS ON MATERIALS**

**I STANDARD CONSISTENCY OF CEMENT:**

To determine the quantity of water required to produce a cement paste of standard consistency. Standard consistency is defined as that consistency which will permit the Vicat's plunger to penetrate to a point 5 to 7 mm from the bottom of the Vicat mould when the cement is tested. The Vicat's apparatus consists of a frame and a moving rod weighing 400 gm. The plunger is kept at the lower end of the rod. It is a cylinder 10 mm. Diameter, A pointer connected to the rod will move along with it when it is released, over a graduated scale kept in front of it. The cement paste to be tested is

kept in the Vicat's mould kept below the rod on a glass plate.

**PROCEDURE:**

1. Carefully weigh 400 gm of cement and place it on a non-porous surface.
2. Form a crater in the center in which add about 100 to 120 cc. of water.
3. Thoroughly mix the cement with water and fill, the Vicat's mould with the paste.
4. The interval from the moment of adding water to the dry cement to the moment of commencing to fill the mould is known as the time of gauging and shall not be less than 3 minutes and more than 5 minutes. Lower the plunger gently and test the penetration.

5. If the penetration is between 5 to 7 mm from the bottom of the mould the quantity of water added is the required consistency.
6. Otherwise repeat the test with different percentages of water until the required

penetration is obtained. Express the amount of water as a percentage by weight of the dry cement.

### OBSERVATIONS:

| S. No. | Weight of Cement W1 | Weight of water W2 | Reading on scale Mm | W2 / W1 | Standard consistency |
|--------|---------------------|--------------------|---------------------|---------|----------------------|
| 1      | 400 gram            | 100 ml             | 15 mm               | 0.25    | 25%                  |
| 2      | 400 gram            | 120 ml             | 13.5 mm             | 0.3     | 30%                  |
| 3      | 400 gram            | 160 ml             | 10 mm               | 0.4     | 40%                  |
| 4      | 400 gram            | 180 ml             | 7 mm                | 0.45    | 45%                  |
| 5      | 400 gram            | 200 ml             | 5 mm                | 0.5     | 50%                  |

### CALCULATIONS:

Weight of cement taken=W1.

Weight of water added when the plunger has a penetration of 5 to 7 mm from the bottom of the mould = W2

Percentage of water for standard consistency p  
= (W2 / W1) x 100

( 180/400)x100= 0.45x100 =45%

### RESULT:

Percentage of water for standard consistency is =45%

## **II SETTING TIME OF CEMENT:**

1. Preparation of Test Block: Prepare a neat cement paste by gauging the cement with 0.85 times the water required to give the paste of standard consistency. Start a stopwatch at the instant when water is added to the cement. Fill the Vicat's mould with a cement paste within three to five minutes after addition of water. Fill the mould completely and smooth off the surface of this paste making it level with the top of the mould. The cement block thus prepared in the mould is test block.

2. Clean appliances shall be used for gauging. The temperature of water and that of the test room at the time of gauging shall be within(27±2)0C.

3. During the test the block shall be kept at a temperature of (27±2)0C and at least 90% relative humidity.

### **a) Determination of Initial Setting Time:**

Place the test block confined in the mould and resting on the nonporous plate, under the rod bearing the needle, lower the needle gently in contact with the surface of the test block and quickly release, allowing it to penetrate into the test block. In the beginning the needle will completely pierce the test block. Repeat this procedure until the needle, when brought in contact with the test block and released as described above, fails to pierce the block for 5 to 7 mm measured from the bottom of the mould. The period elapsing between the time when water is added to the cement and this time shall be initial setting time.

### **b) Determination of Final Setting Time:**

Replace the needle of the Vicat's apparatus with the needle with a circular attachment. The cement shall be considered as finally set, when upon lowering the needle gently to the surface of the test block the needle makes an impression there on, while the attachment fails to do so. In other words the paste has attained such hardness that the centre needle does not pierce through the paste more than0.5mm. The period elapsing between the time when water is added to the cement and the time at which the needle makes an impression on the surface on the test block while the attachment fails to do so shall be the final setting time.

**OBSERVATIONS:**

**INITIAL SETTING TIME:**

| S. No. | Time       | Reading on the scale of Vicat's apparatus |
|--------|------------|---|
| 1      | 10 minutes | 12 mm                                     |
| 2      | 20 minutes | 10 mm                                     |
| 3      | 30 minutes | 7 mm                                      |

**FINAL SETTING TIME:**

| S. No. | Time        | Reading on the scale of Vicat's apparatus |
|--------|-------------|---|
| 1      | 120 minutes | 4mm                                       |
| 2      | 300 minutes | 2.5mm                                     |
| 3      | 600 minutes | 0.5 mm                                    |

**RESULT:**

Initial setting time of the cement= 30 minutes

Final setting time of the cement=600minutes

**III SPECIFIC GRAVITY OF CEMENT:**

Specific gravity of cement is defined as the ratio of weight of a given volume of cement at a given temperature to the weight of an equal volume of distilled water at the same temperature both weights being taken in air.

1. Wt. of empty dry specific gravity bottle = W1
2. Wt. of bottle+ Cement(filled 1/4 to 1/3) = W2
3. Wt. of bottle + Cement (Partly filled ) + Kerosene = W3
4. Wt. of bottle + Kerosene (full). = W4
5. Wt. of bottle + water (full) = W5

$$W1 = 0.640 \text{ kg}$$

$$W2 = 0.820 \text{ kg}$$

$$W3 = 1.580 \text{ kg}$$

$$W4 = 1.600 \text{ kg}$$

$$W5 = 1.600 \text{ kg}$$

$$\text{Specific gravity of kerosene } S_k = (W4 - W1) / (W5 - W1)$$

$$= 0.96$$

$$(W2 - W1) \times S_k$$

$$\text{Specific gravity of Cement} = \frac{\text{-----}}{(W_4 - W_1) - (W_3 - W_2)}$$

$$\frac{(0.820-0.640) \times 0.96}{(1.6-0.64) - (1.58-0.82)}$$

**RESULT:**

Specific Gravity of Cement is =3.1

**IV COMPRESSIVE STRENGTH OF CEMENT:**

1. Standard sand: It shall pass the 850 micron I.S. sieve and not more than 10% by weight shall pass the 600 micron I.S. sieve. Take 200 gms of cement and 600 gms of standard sand in a pan. Mix it dry with a trowel for one minute and then add water. The quantity of water shall be (0.25 P + 3) percent of combined weight of cement and sand, where P is the % of water required to produce a paste of standard consistency determined earlier. Add water and mix it until the mixture is of uniform color. The time of mixing shall not be less than 3 minutes and not greater than 4 minutes.

2. Immediately after mixing the mortar place the mortar in the cube mould and tamp with the help of the tamping rod. The mortar shall be rodded 20 times in about 8 seconds to ensure elimination of entrained air.

3. If vibrator is used the period of vibration shall be two minutes at the specified speed of 12000 vibration per minutes.

4. Then place the cube moulds in an atmosphere of 270 20c and 90% relative humidity, submerge in clear fresh water till testing.

5. Take out the cubes from water just before testing. Testing should be done on their sides with out any packing. The rate of loading should be uniform and of 350kg/cm<sup>2</sup>/minute.

6. Three cubes should be tested and their average should be taken as the test result. Report the result in Kg/cm<sup>2</sup>.

**RESULT:**

The compressive strength of cement concrete is 52 N/mm<sup>2</sup>.

**MORTAR CUBE COMPRESSIVE TEST ON CONCRETE**

1. Place the cube at the centre of the lower platen of the compression testing machine in such a manner that the load shall be applied to opposite sides of the cube as cast, that is, not to the top and bottom.

2. The axis of the specimen shall be carefully aligned with the centre of the thrust of the spherically seated platen. No packing shall be used between the faces of the test specimen and the steel platen of the testing machine.

3. The load shall be applied without shock and increased continuously at a rate of approximately 140kg/cm<sup>2</sup>/min. until the resistance of the specimen to the increasing load breaks down and no greater load can be sustained.

4. The maximum load applied to the specimen shall then be recorded

**OBSERVATION:**

|                          |                    |
|--------------------------|--------------------|
| Measured side of cube    | = 70.6x70.6x70.6mm |
| Weight of the cube       | = 8.780 kg.        |
| Load at first crack      | = 800 KN           |
| Load at ultimate failure | = 900 KN           |

**RESULT:**

Compressive Strength on Concrete =32 N/mm<sup>2</sup>

**TEST ON AGGREGATES**

**I. AGGREGATE CRUSHING VALUE TEST:**

The aggregate passing 12.5 mm sieve and retained on 10 mm IS sieve is selected for standard test. The aggregate should be in surface dry condition before testing. The aggregate may be dried by heating at a temperature 100o C for a period of 4 hours and is tested after being cooled to room temperature. The cylindrical measure is filled by the test sample of aggregate in three layers of approximately equal depth, each layer being tamped 25 times by the rounded end of the tamping rod. After the third layer is tamped, the aggregate at the top of the cylindrical measure is leveled off by using the tamping rod as a straight edge. About 6.5 kg of aggregate is required for preparing two test samples. The test sample thus taken is then weighed. The same



weight of the sample is taken in the repeat test. The cylinder of the test apparatus is placed in position on the base plate; one third of the test sample is placed in the cylinder and tamped 25 times by the tamping rod. Similarly, the other two parts of the test specimen are added, each layer being subjected to 25 blows. The total depth of the material in the cylinder after tamping shall however be 10cm.

The surface of the aggregate is leveled and the plunger inserted so that it rests on this surface in level position. The cylinder with the test sample and plunger in position is placed on compression testing machine. Load is then applied through the plunger at a uniform rate of 4 tones per minute until the total load is 40 tones, and then the load is released. Aggregates including the crushed portion are removed from the cylinder and sieved on a 2.36 mm IS sieve. The material which passes this sieve is collected. The above crushing test is repeated on second sample of the same weight in accordance with above test procedure. Thus two tests are made for the same specimen for taking an average value.

#### **CALCULATION:**

Total weight of dry sample taken =  $W_1$  10.66gm.  
 Weight of the portion of crushed material passing 2.36mm IS sieve =  $W_2$   
 0.100 gm Aggregate crushing value  

$$= \frac{100}{W_2} \times W_1$$

#### **RESULT:**

The Aggregate crushing value is =15.15%

#### **APPLICATIONS OF AGGREGATE CRUSHING TEST:**

The aggregate crushing value is an indirect measure of crushing strength of the aggregates. Low aggregate crushing value indicates strong aggregates, as the crushed fraction is low. Thus the test can be used to assess the suitability of aggregates with reference to the crushing strength for various types of pavement components. The aggregates used for the surface course of pavements should be strong enough to withstand the high stresses due to wheel loads, including the steel tyres of loaded bullock-carts.

However as the stresses at the base and sub-base courses are low aggregates with lesser crushing strength may be used at the lower

layers of the pavement. Indian Roads Congress and ISI have specified that the aggregate crushing value of the coarse aggregates used for cement pavement at surface should not exceed 30 percent. For aggregates used for concrete other than for wearing surfaces, the aggregate crushing value shall not exceed 45 percent, according to the ISS. However aggregate crushing values have not been specified by the IRC for coarse aggregates to be used in bituminous pavement construction methods.

#### **II. AGGREGATE IMPACT VALUE TEST:**

The test sample consists of aggregates passing 12.5 mm sieve and retained on 10 mm sieve and dried in an oven for four hours at a temperature 1000 C to 1100 C and cooled. The aggregates are filled up to about one-third full in the cylindrical measure and tamped 25 times with rounded end of the tamping rod. Further quantity of aggregates is struck off using the tamping rod as straight edge. The net weight of the aggregates in the measure is determined to the nearest gram and this weight of the aggregates is used for carrying out duplicate test on the same material. The impact machine is placed with its bottom plate flat on the floor so that the hammer guide columns are vertical. The cup is fixed firmly in position on the base of the machine and the whole of the test sample from the cylindrical measure is transferred to the cup and compacted by tamping with 25 strokes. The hammer is raised until its lower face is 38 cm above the upper surface of the aggregates in the cup, and allowed to fall freely on the aggregates. The test sample is subjected to a total of 15 such blows, each being delivered at an interval of not less than one second. The crushed aggregate is then removed from the cup and the whole of it sieved on the 2.36 mm sieve until no further significant amount passes. The fraction passing the sieve is weighed accurate to 0.1 g. The fraction retained on the sieve is also weighed and if the total weight of the fractions passing and retained on the sieve is added, it should not be less than the original weight of the specimen by more than one gram; if the total weight is less than the original by over one gram, the result should be discarded and a fresh test made. The above test is repeated on fresh aggregate sample.

**RESULT:** The Impact Value of given Aggregate is =15.98 %  
 The Impact Value of given Aggregate is =15.98 %

TABLE 1:  
 Maximum Allowable Impact Value of Aggregate in Different Types of Pavement Material/Layers

| Serial No. | Types of pavement material/layer   | Aggregate impact value, maximum % |
|------------|--|-----------------------------------|
| 1          | Water bound macadam(WBM), sub-base course  | 50                                |
| 2          | Cement concrete, base course ( as per ISI )  | 45                                |
| 3          | (i) WBM base course with bitumen surfacing<br>(ii) Built up-spray grout, base course   | 40                                |
| 4          | Bituminous macadam, base course  | 35                                |
| 5          | (i) WBM, surfacing course<br>(ii) Built-up spray grout, surfacing course<br>(iii) Bituminous penetration macadam<br>(iv) Bituminous macadam, bindercourse<br>(v) Bituminous surface dressing<br>(vi) Bituminous carpet<br>(vii) Bituminous/ Asphaltic concrete<br>(viii) Cement concrete, surface course | 30                                |

**III. SPECIFIC GRAVITY AND WATER ABSORPTION TEST:**

To find out the specific gravity and water absorption of the given aggregate. About 2 Kg of the aggregate sample is washed thoroughly and placed in the wire basket when immersed in distilled water. The basket and the sample are then weighed (W1) while suspended in water at a temp of 22oC to 32oC. The aggregates are then placed on the absorbent clothes and should be cleaned. The surface dry an aggregate is then weighed (W2). The aggregate is placed in a shallow tray and kept in an oven maintained at a temp of 110oC for 24 hours. It is then removed from the oven, cooled in an air tight container and weighted(W4).

**OBSERVATIONS:**

Weight of saturated aggregate suspended in water with the basket = W1 (620gram)

Weight of basket above suspended in water =W2 (400 gram ) Weight of saturated aggregate in water =(W1-W2) (220gram)  
 Weight of saturated surface dry aggregate in air =W3 (1.14 kg) Weight of Water equal to the volume of the aggregate = w4 (1.96 kg )

**RESULT:**

The Specific Gravity of Coarse Aggregate is =2.72  
 The Water Absorption of Coarse Aggregate is =11.5%

**IV. LOS ANGELES ABRASION TEST:**

The apparatus consists of Los Angeles machine, abrasive charge and sieves. Los Angeles machine consists of a hollow steel cylinder, closed at both ends, having an inside diameter 70cm and an inside length of 50 cm, mounted

on stub shafts about which it rotates on a horizontal axis. An opening is provided in the cylinder for the introduction of the test sample. A removable cover of the opening is provided in such a way that when closed and fixed by bolts and nut, it is dust-tight and the interior surface is perfectly cylindrical. A removable steel shelf projecting radial 8.8 cm into the parallel to the axis. The shelf is fixed at a distance of 12.5 cm from the opening, measured along the circumference in the direction of rotation. Abrasive charge, consisting of cast iron spheres approximately 4.8 cm in diameter and 390 to 445 g in weight are used. The weight of the sphere of the aggregates tested. The aggregates grading have been standardized as A, B, C, D, E, F and G for this test and the IS specifications for the grading and abrasive charge to be used are given in Table IS sieve with 1.70 mm opening is used for separating the fines after the abrasion test.

Clean aggregates dried in an oven at 105-1100 C to constant weight, conforming to any one of the grading A to G, as per Table 11.1 is used for the test. The grading or grading's used in the test should be nearest to the grading to be used in the construction. Aggregates weighing 5 kg

for grading A, B, C or D and 10 kg for grading E, F or G may be taken as test specimen and placed in the cylinder. The abrasive charge is also chosen in accordance with Table 1 depending on the grading of the aggregate and is placed in the cylinder of the machine. The cover is then fixed dust-tight. The machine is rotated at a speed of 30 to 33 revolutions per minute. The machine is rotated for 500 revolutions for grading A, B, C and D, for grading's E, F and G, it shall be rotated for 1,000 revolutions. The machine should be balanced and driven in such a way as to maintain uniform peripheral speed. After the desired number of revolutions, the machine is stopped and the material is discharged from the machine taking care to take out entire stone dust. Using a sieve of size larger than 1.70 mm IS sieve, 1.7 mm IS sieve. The portion of material coarser than 1.7 mm size is washed and dried in an oven at 105 to 1100 C to constant weight and weighed correct to one gram.

**CALCULATION:**

The difference between the original and final weights of the sample is expressed as percentage of the original weight of the sample is reported as the percentage wear.

TABLE 1:  
Specifications for Los Angeles Test

| Grade | Weight in grams of each test sample in the size range, mm<br>(Passing and retained on square holes) |       |       |       |       |         |         |        |          |           | Abrasive Charge |               |
|-------|---|-------|-------|-------|-------|---------|---------|--------|----------|-----------|-----------------|---------------|
|       | 80-63   | 63-50 | 50-40 | 40-25 | 25-20 | 20-12.5 | 12.5-10 | 10-6.3 | 6.3-4.75 | 4.75-2.36 | No. of Spheres  | Wt. of charge |
| A     | -   | -     | -     | 1250  | 1250  | 1250    | 1250    | -      | -        | -         | 12              | 5000 ±25      |
| B     | -   | -     | -     | -     | -     | 2500    | 2500    | -      | -        | -         | 11              | 4584 ±25      |
| C     | -   | -     | -     | -     | -     | -       | -       | 2500   | 2500     | -         | 8               | 3330 ±20      |
| D     | -   | -     | -     | -     | -     | -       | -       | -      | -        | 5000      | 6               | 2500 ±15      |
| E     | 2500*   | 2500* | 5000* | -     | -     | -       | -       | -      | -        | -         | 12              | 5000 ±25      |

|   |   |   |           |           |           |   |   |   |   |   |    |             |
|---|---|---|-----------|-----------|-----------|---|---|---|---|---|----|-------------|
| F | - | - | 5000<br>* | 5000<br>* | -         | - | - | - | - | - | 12 | 5000<br>±25 |
| G | - | - | -         | 5000<br>* | 5000<br>* | - | - | - | - | - | 12 | 5000<br>±25 |

\* Tolerance of percent is permitted.

Let the original weight of aggregate = W<sub>1</sub> 5kg

Weight of aggregate retained on 1.70 mm IS sieve after the test = W<sub>2</sub> 1.26 kg Loss in

weight due to wear

$$= (W_1 - W_2) \times 100$$

$$= (5 - 1.26) \times 100$$

$$= 25.2\%$$

**RESULT:**

The Average Value of Los Angles Abrasion Test is = 25.2 %

**TABLE 1:**

Maximum Allowable Los Angeles Values of Aggregates in Different Types of Pavement Layers

| Serial No. | Types of pavement layer  | Los Angeles abrasion value, maximum % |
|------------|--|---------------------------------------|
| 1          | Water Bound Macadam(WBM), sub-base course  | 60                                    |
| 2          | (i) WBM base course with bituminous surfacing<br>(ii) Bituminous Macadam base course<br>(iii) Built-up spray grout base course   | 50                                    |
| 3          | (i) WBM surfacing course<br>(ii) Bituminous Macadam binder course<br>(iii) Bituminous penetration<br>(iv) Macadam Built-up spray grout binder course   | 40                                    |
| 4          | (i) Bituminous carpet surface course<br>(ii) Bituminous surface dressing, single or two coats<br>(iii) Bituminous surface dressing, using pre-coated aggregates.<br>(iv) Cement concrete surface course ( as per IRC ) | 35                                    |
| 5          | (i) Bituminous/Asphalt concrete surface course<br>(ii) Cement concrete pavement surface course ( as per ISI )  | 30                                    |

**I. AGGREGATE SHAPE TEST:**

**a) FLAKINESS INDEX:**

The sample is sieve with the sieves mentioned in Table 1. A minimum of 200 pieces of each fraction to be tested are taken and weighed = W<sub>1</sub> g. In order to separate flaky materials, each fraction is then gauged for thickness on a

thickness gauge shown in Fig. 15.1 or in bulk on sieves having elongated slots. The width of the slot should be of the dimensions specified in column (3) of Table 15.1 for the appropriate size of material. The amount of flaky material passing the gauge is weighed to an

accuracy of at least 0.1 percent of the test sample.

**TABLE 1:**

Dimensions of Thickness and Length Gauges

| Size of aggregate           |                         | (a) Thickness gauge (0.6 times the mean sieve), mm | (b) Length gauge (1.8 times the mean sieve) mm |
|-----------------------------|-------------------------|--|--|
| Passing through IS sieve Mm | Retained on IS sieve Mm |  |  |
| 1                           | 2                       | 3  | 4  |
| 63.0                        | 50.0                    | 33.90  | -  |
| 50.0                        | 40.0                    | 27.00  | 81.0   |
| 40.0                        | 25.0                    | 19.50  | 58.5   |
| 31.5                        | 25.0                    | 16.95  | -  |
| 25.0                        | 20.0                    | 13.50  | 40.5   |
| 20.0                        | 16.0                    | 10.80  | 32.4   |
| 16.0                        | 12.5                    | 8.55   | 25.6   |
| 12.5                        | 10.0                    | 6.75   | 20.2   |
| 10.0                        | 06.3                    | 4.89   | 14.7   |

**CALCULATION AND RESULT:**

In order to calculate the flakiness index of the entire sample of aggregates first the weight of each fraction of aggregate passing and retained on the specified set of sieves is noted. As an example let 200 pieces of the aggregate passing 50 mm sieve and retained on 50 mm sieve be = W<sub>1</sub>g. Each of the particles from this fraction of aggregate is tried to be passed through the slot of the specified thickness of the thickness gauge; in this example the width of the appropriate gauge of the thickness gauge is 27.0 mm gauge. Let the weight of the flaky material passing this gauge be W<sub>1</sub>g. Similarly the weights of the fractions passing and retained the specified sieves, W<sub>1</sub>, W<sub>2</sub>, W<sub>3</sub>, etc., are weighed and the total weight W<sub>1</sub>+W<sub>2</sub>+W<sub>3</sub>+...- W g is found. Also the weights of materials passing each of the specified thickness gauge are found = W<sub>1</sub>, W<sub>2</sub>, W<sub>3</sub>... and the total weight of material passing the different

thickness gauges = W<sub>1</sub>+ W<sub>2</sub> +W<sub>3</sub>+ ... = W g is found. Then the flakiness index is the total weight of the flaky material passing the various thickness gauges expressed as a percentage of the total weight of the sample gauged.

Flakiness Index =  $(w_1 + w_2 + w_3 + \dots) / W \times 100$  percent = 12.6%

**a) ELONGATION INDEX:**

The elongation index of an aggregate is the percentage by weight of particles whose greatest dimension (length) is greater than one and four fifth times (1.8 times) their mean dimension. The elongation test is not applicable to sizes smaller than 6.3 mm. The sample is sieved through the IS sieves specified in Table 15.1. A minimum of 200 pieces of each fraction is taken and weighed. In order to separate elongated material, each fraction is then gauged individually for length in a length gauge.

The gauge length used should be those specified in column 4 of the Table for the appropriate material. The pieces of aggregates from each fraction tested which could not pass through the specified gauge length with its long side are elongated particles and are collected separately to find the total weight of aggregate retained on the length gauge from each fraction. The total amounts of elongated material retained by the length gauge are weighed to an accuracy of at least 0.1 percent of the weight of the test sample.

**CALCULATION AND RESULT:**

In order to calculate the elongation index of the entire sample of aggregates, the weight of aggregates which is retained on the specified gauge length from each fraction is noted. As an example, let 200 pieces of the aggregate passing 40 mm sieve and retained 25 mm sieve W1 g. Each piece of these are tried to be passed through the specified gauge length of length gauge, which in this example is  $(40+25)/2 \times 1.8 = 58.5$  mm with its longest side and those elongated pieces which do not pass the gauge are separated and the total weight determined = w1 g. Similarly the weight of each fraction of aggregate passing and retaining on specified sieves sizes are found, W1,W2W3... and the total weight sample determined =  $W1+ W2 +W3+ \dots = Wg$

Also the weight of material from each fraction retained on the specified gauge length are found =  $x1,x2,x3\dots$  and the total weight retained

determined =  $x1+x2+x3+\dots = Xg..$  The elongation index is the total weight of the material retained on the various length gauges, expressed as a percentage of the total weight of the sample gauged.

$$\text{Elongation Index} = \frac{(x1+x2+x3) 100}{W1+W2+W3+\dots} = 100 \times \frac{X}{W} = 19.6\%$$

**COMPRESSIVE STRENGTH OF CEMENT WITH ADMIXTURES FLYASH**

1. Place the cube at the center of the lower platen of the compression testing machine in such a manner that the load shall be applied to opposite sides of the cube as cast, that is, not to the top and bottom.
2. The axis of the specimen shall be carefully aligned with the centre of the thrust of the spherically seated platen. No packing shall be used between the faces of the test specimen and the steel platen of the testing machine.
3. The load shall be applied without shock and increased continuously at a rate of approximately 140kg/cm<sup>2</sup>/min. until the resistance of the specimen to the increasing load breaks down and no greater load can be sustained.
4. The maximum load applied to the specimen shall then be recorded
5. Cement is gradually reduced and FLYASH is added.

**TABULATION**

| S.NO | PERCENTAGE OF FLYASH | COMPRESSIVE STRENGTH AT 28 <sup>TH</sup> DAY TESTING |
|------|----------------------|--|
| 1    | 5%                   | 36 N/mm <sup>2</sup>                                 |
| 2    | 6%                   | 40 N/mm <sup>2</sup>                                 |
| 3    | 7%                   | 46 N/mm <sup>2</sup>                                 |
| 4    | 8%                   | 50 N/mm <sup>2</sup>                                 |
| 5    | 9%                   | 54 N/mm <sup>2</sup>                                 |
| 6    | 10%                  | 56 N/mm <sup>2</sup>                                 |

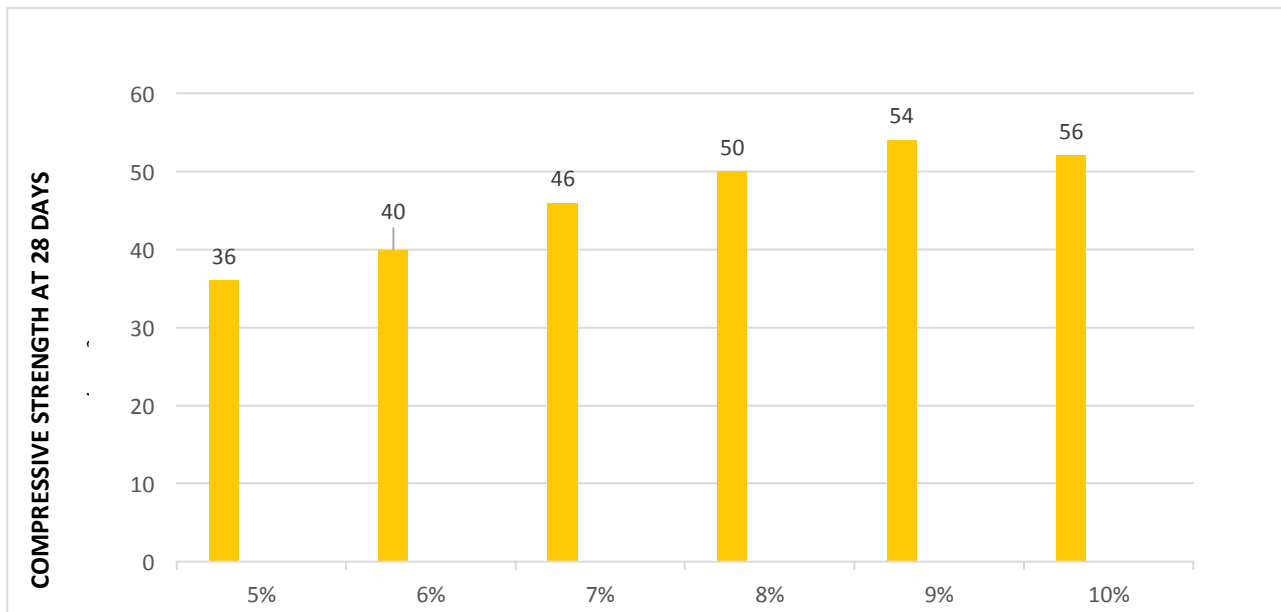
**BAR CHART ANALYSIS**

### RESULT ANALYSIS FLEXURAL TEST ON RETROFITTED BEAM:

o This test method is used to determine the flexural strength of specimens prepared and cured in accordance with the specifications. Results are calculated and reported as the modulus of rupture.

o The strength determined will vary where there are differences in specimen size, preparation, moisture condition, curing, or where the beam has been molded or swayed to size.

o The results of this test method may be used to determine compliance with specifications or as a basis for proportioning, mixing and placement operations. It is used in testing concrete for the construction of slabs and pavements.

o The modulus of rupture is also used as an indirect measure of the tensile strength of concrete.

- The objective of this test is to determine flexural strength of concrete using simple beam with third-point loading.

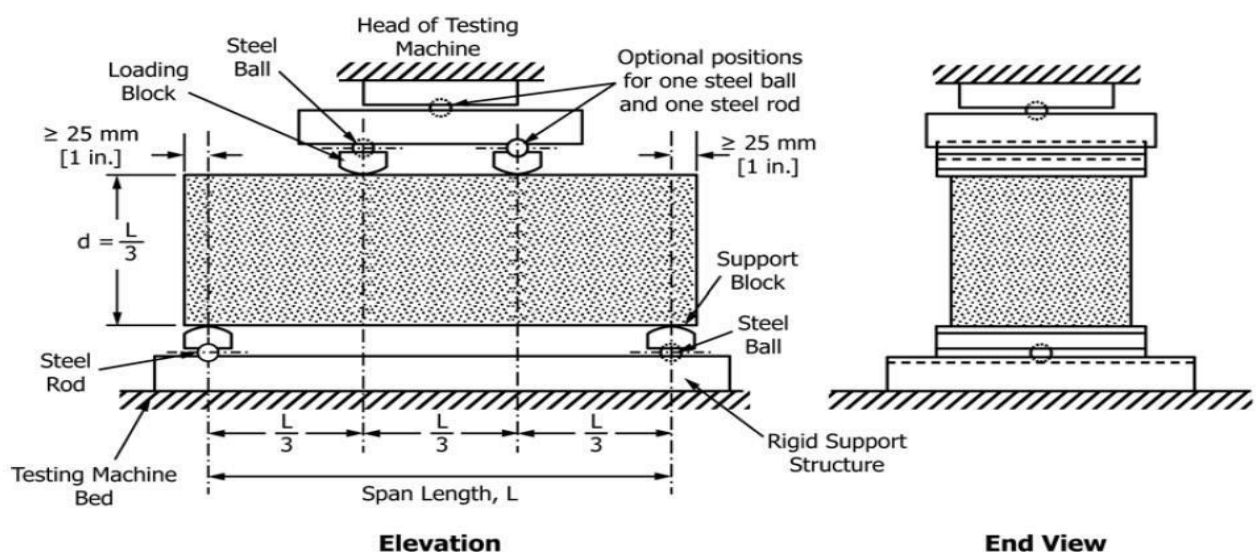

1) Flexural strength is one measure of the tensile strength of concrete. It is a measure of an unreinforced concrete beam or slab to resist failure in bending. It is measured by loading 6 x 6-inch (150 x 150-mm) concrete beams with a span length at least three times the depth. The flexural strength is expressed as Modulus of Rupture (MR) in psi (MPa) and is determined by standard test methods ASTM C 78 (third-point loading) or ASTM C 293 (center-point loading).

2) Flexural MR is about 10 to 20 percent of compressive strength depending on the type, size and volume of coarse aggregate used. However, the best correlation for specific materials is obtained by laboratory tests for given materials and mix design. The MR determined by third-point loading is lower than the MR determined by center-point loading, sometimes by as much as 15%.

3) Designers of pavements use a theory based on flexural strength. Therefore,

laboratory mix design based on flexural strength tests may be required, or a cementitious material content may be selected from past experience to obtain the needed design MR. Some also use MR for field control and acceptance of pavements. Very few use flexural testing for structural concrete. Agencies not using flexural strength for field control generally find the use of compressive strength convenient and reliable to judge the quality of the concrete as delivered.

4) Specifications and investigation of apparent low strengths should take into account the higher variability of flexural strength results. Standard deviation for concrete flexural strengths up to 800psi (5.5MPa) for projects with good control range from about 40 to 80 psi (0.3 to 0.6MPa). Standard deviation values over 100psi (0.7MPa) may indicate testing problems. There is a high likelihood that testing problems or moisture differences within a beam caused from premature drying will cause low strength.

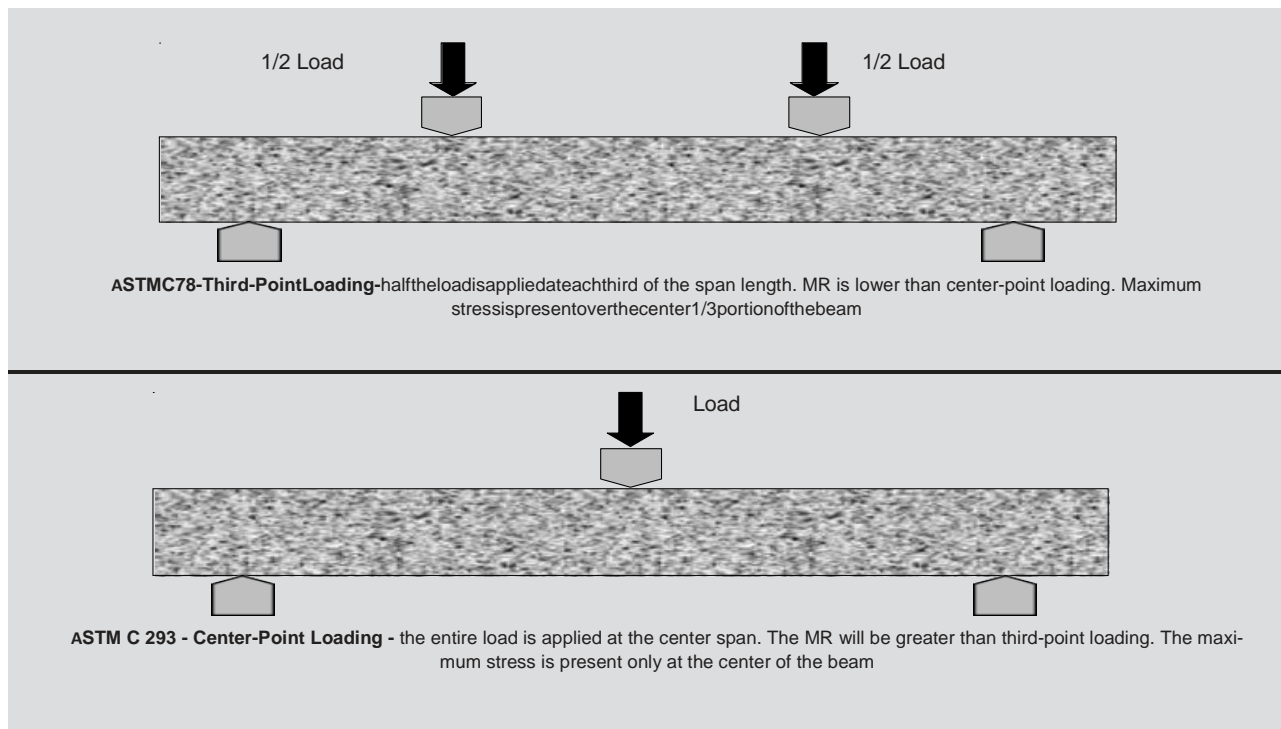

### Testing method:

To evaluate bending performance of beam with flexural-strengthened expansive SHCC, experiment objects were installed as shown in Fig. 3. Three SDTs were installed in the middle to measure deflection of the beam, and three crack gauges were attached to lower part of beam while one was to upper part to measure

crack width. In addition, 2-axis gauge and concrete gauge were attached to boundary surface between SHCC strengthen and concrete to measure deflection of SHCC strengthen and concrete interface, while a gauge was installed on tensile and compression side reinforcement bar of beam to measure deformation rate of the bar. Monotonic 4 point loading was carried out



by using deformation control method with 500 k N actuator to measure loading of the beam.

### Related Theory:

Difficulties in determining Tensile Strength of Concrete:

There are considerable experimental difficulties in determining the true tensile strength of concrete. In direct tension test following are the difficulties:

- When concrete is gripped by the machine it may be crushed due the large stress concentration at the grip.
- Concrete samples of different sizes and diameters show large variation in results.
- If there are some voids in sample the test may show very small strength.
- If there is some initial misalignment in fixing the sample the results are not accurate.

### Tests for Tensile Strength of Concrete:

Following tests are used to determine the tensile strength of concrete.

- Split Cylinder Test
- Double Punch Test
- Modulus of Rupture Test

### Modulus of Rupture:

In a flexural test on a plane concrete specimen, the maximum tensile stress reached at the bottom fiber of a standard size prism (beam) under predefined loading type is called modulus of rupture.

### Type / Size of the Specimen for the Test:

The specimen used is a prism, square in cross-section and having a certain length. There are two standard sizes of the specimen that can be used for specified aggregate sizes.

- 1) 150 x 150 x 1000(mm)
- 2) 100 x 100 x 500 (mm)

- The size (150 x 150 x 1000 mm) can be used for all sizes of the aggregate particles.
- The size (100 x 100 x 500 mm) can only be used for the aggregate sizes less than 25mm. We are using this size for our test.

### Procedure:

I. Flexural tests of moist-cured specimens shall be made as soon as practical after removal

from moist storage. Surface drying of the specimen results in a reduction in the measured flexural strength.

II. When using molded specimens, turn the test specimen on its side with respect to its position as molded and center it on the support blocks. When using sawed specimens, position the specimen so that the tension face corresponds to the top or bottom of the specimen as cut from the parent material. Center the loading system in relation to the applied force. Bring the load-applying blocks in contact with the surface of the specimen at the third points and apply a load of between 3 and 6 % of the estimated ultimate load or as per ASTM standard.

III. Grind, cap, or use leather shims on the specimen contact surface to eliminate any gap in excess of 0.004 in. (0.10 mm) in width. Gaps in excess of 0.015 in. (0.38 mm) shall be eliminated only by capping or grinding. Grinding of lateral surfaces should be minimized in as much as grinding may change the physical characteristics of the specimens. Capping shall be in accordance with the applicable sections of Practice C617.

IV. Load the specimen continuously and without shock. The load shall be applied at a constant rate to the breaking point. Apply the load at a rate that constantly increases the extreme fiber stress between 125 and 175 psi/min (0.86 and 1.21 MPa/min) until rupture occurs. The loading rate is calculated using the following equation:

### Calculations:

If the fracture initiates in the tension surface within the middle third of the span length, calculate the modulus of rupture as follows:

$$R = PL / bd^2$$

Where:

R = modulus of rupture, psi or MPa,

P = maximum applied load indicated by the testing machine, lbf L = span length, inch or mm,

b = average width of specimen, inch or mm, at the fracture, and

d = average depth of specimen, inch or mm, at the fracture.

$R = 98500 \times 1 / (0.15 \times 0.15)^2$  R = 19.4 MPa

Note: The weight of the beam is not included in the above calculation.

RESULT

| SPECIMEN                 | SPECIMEN NO | ULTIMATE LOAD (KN) | ULTIMATE LOAD AVERAGE | MODULUS OF RUPTURE ( MPa) | MODULUS OF RUPTURE AVERAGE | TOUGHNESS |
|--------------------------|-------------|--------------------|-----------------------|---------------------------|----------------------------|-----------|
| CONVENTIONAL BEAM        | SC 1        | 98.5               | 98.16                 | 19.4                      | 18.86                      | 25.27     |
|                          | SC 2        | 98                 |                       | 18.6                      |                            |           |
|                          | SC 3        | 98                 |                       | 18.6                      |                            |           |
| RC BEAM WITH FERROCEMENT | SF 1        | 120                | 119.5                 | 20                        | 20.23                      | 40.26     |
|                          | SF2         | 120.5              |                       | 21.4                      |                            |           |
|                          | SF 3        | 118                |                       | 19.3                      |                            |           |

FLEXURAL STRENGTH TEST RESULTS

BAR CHART ANALYSIS

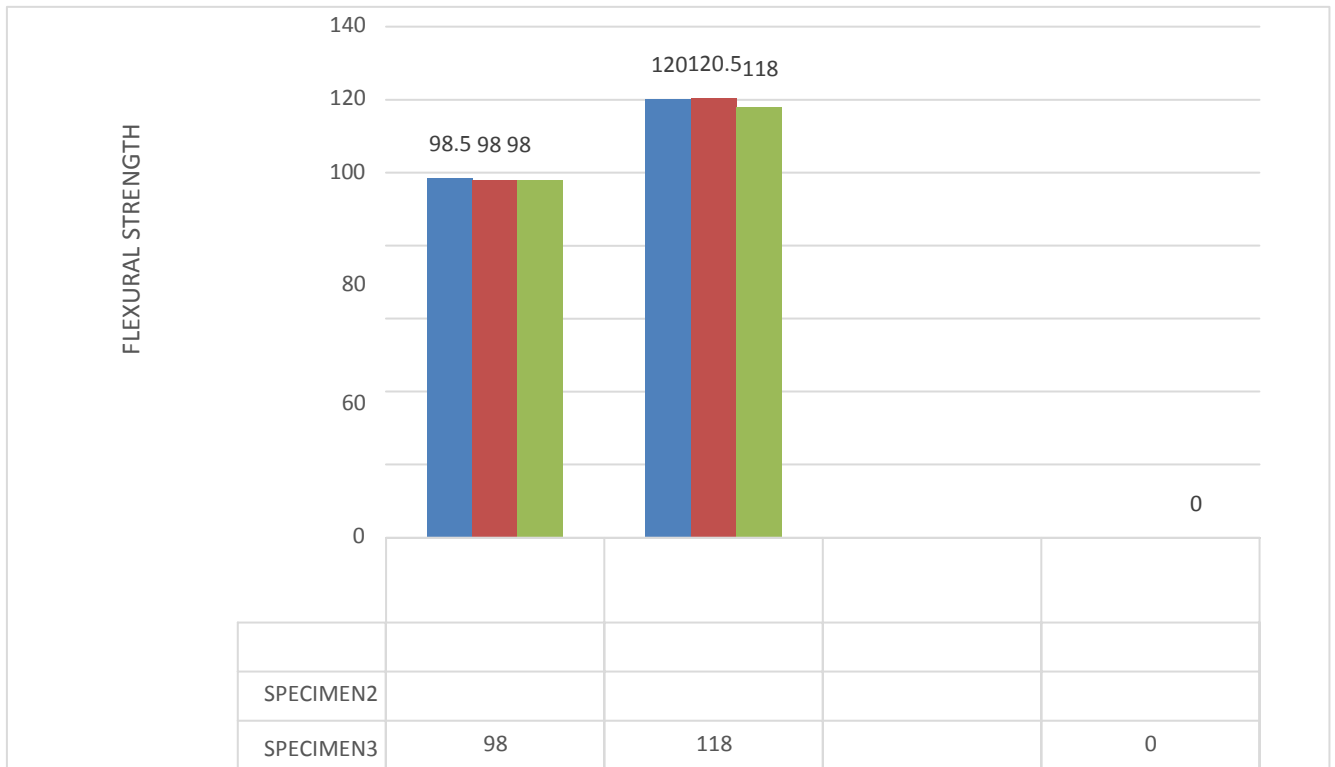

|            | CONVENTIONAL BEAM | RC BEAM WITH FERROCEMENT |
|------------|-------------------|--------------------------|
| SPECIMEN 1 | 98.5              | 120                      |
|            | 98                | 120.5                    |

**CONCLUSION:**

Apart from all the consideration of past journals we have consider that Repair reinforced concrete beams with ferro cement bonding with epoxy resin and partially replacement of Fly ash will gives the more strength than conventional beam.

**REFERENCES:**

1) Toutanji, H., Zhao, L., and Zhang, Y. Flexural behavior of reinforced concrete beams externally strengthened with CFRP sheets bonded with an inorganic matrix. Engineering Structures, 2006; 28:557-566.

2) Ashour, AF, El-Refaie, SA, and Garrity, SW. Flexural strengthening of RC continuous beams using CFRP laminates. Cement & Concrete Composites, 2004; 26: 765-775.

3) Esfahani, M., Kianoush, M., &Tajari, A. Flexural behavior of reinforced concrete beamsstrengthened by CFRP sheets. Engineering Structures, 2007; 29:2428-2444.

4) Khalifa, A., Tumialan, G., Nanni, A. and Belarbi, A., Shear strengthening of continuous RC beams using externally bonded CFRP sheets. American Concrete Institute, Proc., 4thInternational Symposium on FRP for

- Reinforcement of Concrete Structures (FRPRCS4), Baltimore, MD, Nov. 1999:995-1008.
- 5) Obaidat, Y., Heyden, S., Dahlblom, O., Abu-Farsakh, G., and Abdel-Jawad, Y. Retrofitting of reinforced concrete beams using composite laminates. *Construction and Building Materials*, 2011; 25:591–597.
- 6) Garden, H.N., and Hollaway, L.C. An Experimental study of the influence of plate end anchorage of carbon fiber composite plates used to strengthen reinforced concrete beams. *Composite Structures*, 1998; 42 (2): 175-88.
- 7) fib Bulletin 14. Externally bonded FRP reinforcement for RC structures. 2001.
- 8) ACI 440.2R-08. Guide for the design and construction of externally bonded FRP systems for strengthening concrete structures. ACI Committee 440, American Concrete Institute, Farmington Hills, Mich., 2008, 76p.
- 9) Darby, A., Ibell, T., Clarke, J. TR55 Design guidance for strengthening concrete structures using fiber composite materials. London: The Concrete Society, 2004.
- 10) CNR-DT 200: Guide for the design and construction of externally bonded FRP systems for strengthening existing structures, Italian National Research Council, 2004. Täljsten, B. FRP Strengthening of existing concrete structures. Design guidelines.
- 11) Division of Structural Engineering, Lulea University of Technology, Lulea 2002, 228pp, ISBN 91-89580-03-6, 2002.
- 12) <http://www.sika.ie> [19.10.2011].
- 13) <http://www.fosroc.com> [19.10.2011].
- 14) Alcocer, S.M. and Jirsa, J.O. (1993). “Strength of Reinforced Concrete Frame Connections Rehabilitated by Jacketing”, *ACI Structural Journal*, Vol. 90, No. 3, pp.249–261.
- 16) Badari Narayanan, V.T. (2010). “Seismic Retrofit of Reinforced Concrete Beams in Buildings for Sagging Moment Using Concrete Jacket”, Ph.D. Thesis, Department of Civil Engineering, Indian Institute of Technology Madras, Chennai.
- 17) Bhedasaonkar, B.V. and Wadekar, M.K. (1995). “Repairs of Beams and Slab with Excessive Deflection”, *The Indian Concrete Journal*, Vol. 69, No. 1, pp. 47–50.
- 18) BIS (1993). “IS 13920: 1993—Indian Standard Ductile Detailing of Reinforced Concrete Structures Subjected to Seismic Forces—Code of Practice”, Bureau of Indian Standards, New Delhi.
- 19) BIS (2000). “IS 456: 2000—Indian Standard Plain and Reinforced Concrete—Code of Practice (Fourth Revision)”, Bureau of Indian Standards, New Delhi.
- 20) Chakrabarti, A., Menon, D. and Sengupta, A.K. (editors) (2008). “Handbook on Seismic Retrofit of Buildings”, Alpha Science International Ltd., Oxford, U.K.