



DESIGN OF WIRELESS TRANSMISSION SYSTEM USING RF DATA MODEM

Jayalakshmi P K

Abstract

Wireless technology has been tremendously growing day by day. The need of wireless technology is that it replaces the conventional methods including long wires for communication and thereby increasing the redundancy of the whole system. As far as the problems concerned with the wired communications this paper puts forward a new scheme for wireless communication based on RF data modem. It also provides a real time weather monitoring system which will be helpful for travelers. Both the hardware and software part of the system is described here. The system has strong ant interference ability and high reliability by use of At mega 328 microcontroller and RF data modem in hardware design. At the same time, the new method can be achieved with low complexity and computing cost. The key features of program for microcontroller and wireless digital chip configuration and wireless data transmission are discussed. The system has many features, such as low cost, simple structure, easily to control and maintain and stability, it can obtain reliable wireless data transmission.

Keywords: RF data modem; At mega 328; wireless data transmission; Arduino platform; Matlab program

I Introduction:

In the conventional method, the data are usually acquired and transmitted to the computer to analyze and store through the RS485/RS232 or CAN bus. It has many shortcomings in special complex environment. On the one hand, this method using long communication lines to realize data acquisition is not a kind of guaranteed method. On the other hand, the communication lines have high cost of maintaining and many problems can not

be easily detected. Finally, it will inevitably result in loss of data packets and error in severe electromagnetic interference industrial environment transmission. As a result, the safe and effective production cannot be guaranteed. With the development of electronic technology, wireless communication method based on MCU was putted forward in data transmission.[1]. As for these problems, this system uses RF data modem and low cost microcontroller Atmega 328 with Universal Serial BUS to control wireless data communication. The system can not only work with computer, but can achieve data acquisition independently. This wireless communication method uses wireless transmission to indirectly realize data acquisition, and it is an effective method to overcome the disadvantages produced by the wired data transmission method. In addition, the system has many features, such as low cost, simple protocol, easily to maintain and achieve software development.

This paper uses one of the application of wireless communication. We know nowadays people are travelling all around the world, from one place to other. But sometimes bad weather conditions may effect the travelers badly. So there arises a need of a system to monitor the weather conditions and to indicate the travelers properly. This system can be made possible by using the wireless communication method with MCU and RF data modem .This wireless communication method uses wireless transmission to indirectly realize data acquisition and an FM channel to indicate the travelers about the weather conditions.

II . RF Data Modem

RF data modem is a really single chip, low power, multichannel FSK transceiver designed for use in applications requiring FCC or ETSI

conformance for unlicensed use in the 433 MHz band. The RF data modem is the one, which produces a flexible, low cost, and highly integrated solution that does not require production alignments. The chip is a complete analog radio frequency and baseband transceiver including a multi-band PLL synthesizer with PA, LNA, I/Q down converter mixers, baseband filters and amplifiers, and an I/Q demodulator. All required RF functions are integrated. Only an external crystal and bypass filtering are needed for operation. The Si4421 can dramatically reduce the load on microcontroller with fully integrated digital high-speed data processing features, such as: data filtering, clock recovery, data pattern recognition, integrated FIFO and TX data register [2]. The automatic frequency control feature allows the use of a low accuracy (low cost) crystal. To minimize the system cost, the it can provide a clock signal for the microcontroller, avoiding the need for two crystals. SDI is serial data input pin, SDO is serial data output pin, SCK is serial clock input pin and low effective nSEL is chip select signal input pin are the standard 4-wire hardware SPI interface, it can not only take less hardware resources, but the connection between devices is very simple [3]. The SPI bus is a full-duplex synchronous serial peripheral interface, microcontroller can simply communication with a variety of peripheral devices to exchange information in serial mode. IRQ is the interrupt pin. The pin is set low when data packets are completely transmitted out or received from the transmission part, and power-on Reset will occur, at the same time, microcontroller reads the data from the RX FIFO register of data modem.

Here the data transmitted through the RF data modem is used to alert the travelers. So transmission distance is an important role in this. As we know wireless transmission distance is closely related to the reliability of data transmission. Transmission distance of the RF data modem chip can be programmed to adjust to meeting the different requirements of the different communication distance occasions. Because the wireless signal transmission distance in free space and total gain from proportional to the logarithm, so it is very important to select high receiver sensitivity chips for wireless communication.

III. Design of the overall system

The wireless data transmission system consists of three parts: the transmission part, the receiving part and FM channel section. The transmission part makes up of sensors, RF data modem, Atmega328 microcontroller, which used to transmitting the acquired data to the RF data modem to encode after processed by the microcontroller At mega 328, and then the processed data in a specific format for real-time transmission by antenna. The receiving part makes up of RF chip and computer, which receives the data from the transmission part. At the same time, microcontroller reads the data from the FIFO register of RF chip and transfers to computer through the USB bus, the acquired data can display on the computer through the graphical human-machine interface of Matlab. The last part consists of a well designed FM channel that speaker out the data stored in the excel sheet format at receiver section by using Visual basis. So by sensing the weather related data at the transmitter part, one can get the data through the FM channel.

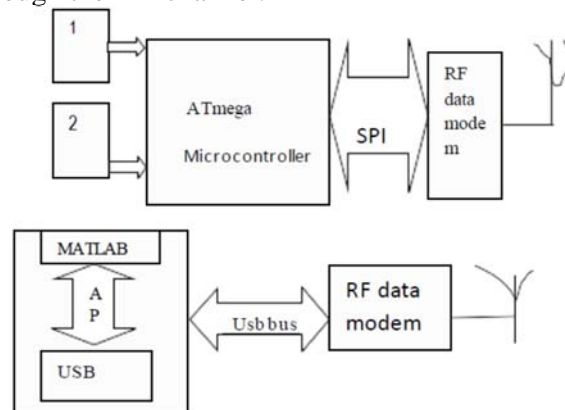

Fig 3.1: Block diagram

Because data modem has a 4 wire hardware SPI interface, therefore, we choose At mega 328 microcontroller with an enhanced hardware SPI interface. It's high-speed pipelined low power micro controller device with ADC, Flash memory and RAM, Watchdog Timer and clock oscillator devices. Finally, the stability and reliability of the system is enhanced due to the complex circuit layout and introduced interference is reduced.

At mega 328 is a low-power CMOS 8-bit microcontroller based on the AVR enhanced RISC architecture[7]. By executing powerful instructions in a single clock cycle, the ATmega328 achieves throughputs approaching 1

MIPS per MHz allowing the system designer to optimize power consumption versus processing speed. The AVR core combines a rich instruction set with 32 general purpose working registers. All the 32 registers are directly connected to the Arithmetic Logic Unit (ALU), allowing two independent registers to be accessed in one single instruction executed in one clock cycle. The resulting architecture is more code efficient while achieving throughputs up to ten times faster than conventional CISC microcontrollers. The AVR core combines a rich instruction set with 32 general purpose working registers. The 328 provides the following features: 4K/8Kbytes of In System Programmable Flash with Read-While-Write capabilities, 256/512/512/1Kbytes EEPROM, 512/1K/1K/2Kbytes SRAM, 23 general purpose I/O lines, 32 general purpose working registers, three flexible Timer/Counters with compare modes, internal and external interrupts, a serial programmable USART, a byte-oriented 2-wire Serial Interface, an SPI serial port, a 6-channel 10bit ADC (8 channels in TQFP and QFN/MLF packages), a programmable Watchdog Timer with internal Oscillator, and five software selectable power saving modes. The Idle mode stops the CPU while allowing the SRAM, Timer/Counters, USART, 2-wire Serial Interface, SPI port, and interrupt system to continue functioning. The Powerdown mode saves the register contents but freezes the Oscillator, disabling all other chip functions until the next interrupt or hardware reset. In Power-save mode, the asynchronous timer continues to run, allowing the user to maintain a timer base while the rest of the device is sleeping. The ADC Noise Reduction mode stops the CPU and all I/O modules except asynchronous timer and ADC, to minimize switching noise during ADC conversions. In Standby mode, the crystal/resonator Oscillator is running while the rest of the device is sleeping. This allows very fast start-up combined with low power consumption. The device is manufactured using Atmel's high density nonvolatile memory technology. The On-chip ISP Flash allows the program memory to be reprogrammed In-System through an SPI serial interface, by a conventional nonvolatile memory programmer, or by an On-chip Boot program running on the AVR core. The Boot program can use any

interface to download the application program in the Application Flash memory. Software in the Boot Flash section will continue to run while the Application Flash section is updated, providing true Read-While-Write operation. By combining an 8-bit RISC CPU with InSystem Self-Programmable Flash on a monolithic chip, the Atmel ATmega328 is a powerful microcontroller that provides a highly flexible and cost effective solution to many embedded control applications.

At mega 328 microcontroller can completely control the RF datamodem for communication and configuration the RF chip, read and write operation and access to FIFO through the enhanced SPI interface. Atmega 328 microcontroller works in the 4-wire SPI master mode, while the data modem works in the 4-wire SPI slave mode. Only the SPI master device initiates all data transfers on the SPI bus, the system can avoid using of two crystals due to data modem generating a clock signal for the master device to use. SCK pin is used to synchronize the serial data transmission between the MOSI and MISO lines. At each falling edge of nSEL and rising edge of SCK, C8051F340 microcontroller transmits the serial data to the Si4421 through MOSI pin; at the same time, Si4421 transmits the serial data to At mega 328 through MISO pin. The most important is all read and write operations can effect only the chip select pin nSEL is set to low, and the data always begin from the most significant bit (MSB) to transmit. The hardware connections at both the transmitter and receiver side is shown below:

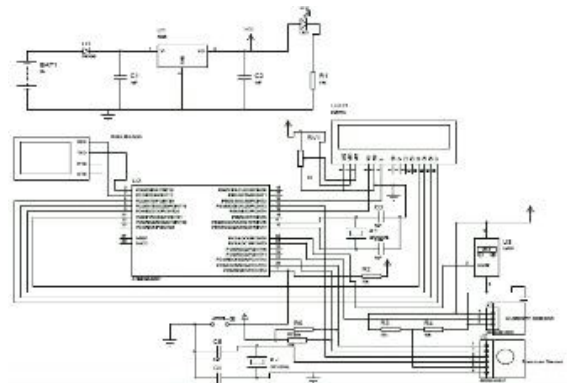

Fig 3.2 Hardwire connection

IV .Introduction to software design

Arduino Uno is the software development environment, the language is Arduino. The system's software design includes program of At

mega 328 microcontroller and RF chip, USB communication, and the design of the Matlab program on the computer and design of FM channel.

A. Hardware Initialization

When the Arduino software is fully installed, software design of the system can greatly simplify if we install the .exe file and hardware setting Configuration Wizard 2. Initialization of the system includes At mega 328 initialization, SPI configuration, data modem transceiver frequency, mode of transmission rate and the related register configuration. The crossbar of the microcontroller can assign internal resource to the I/O pins by setting the crossbar control register, so the resource assignment flexibility is improved. In this system, Microcontroller controls data modem through configuring the SPI registers, At mega 328 is configured as the master SPI device and data modem is configured as the slave device [4]. The most important is initialization of the registers. When initializing the SPI, we can achieve to configure the registers through the Configuration Register, Control Register, Data Register and Clock Frequency Register. In 4wire SPI master mode, all the operation starts at each rising edge of the clock by setting clock register, the register is ignored when operating in slave mode.

B. The Program Points of RF data modem

When the data modem Power-on Reset, all registers are in default values, we can access to these registers and generate initialization code. We must note that a delay of more than 50ms should be executed immediately after Power-on. The purpose is to provide a 10MHz crystal oscillator to start and achieve a stable process, otherwise, it may cause the initialization of the chip unpredictable errors. Set chip select pin low when transmitting the data, control Write Timing to write data to FIFO after starting TX mode. At the same time, we can not close the RF link, because the data have not been transmitted into the air, it is important to add 2 bytes at each packet' end, the useful packet has been transmitted into the air if the last byte has been transmitted out.

C. USB Communication and Design of MATLAB Program on Computer

Matlab is the the Application Programming Interface (API) and program drivers to achieve to read and write operations to USB

devices. USBXpress development Kit contains all the communication functions and protocols between USB host and USB device, which can greatly reduce the application of USB communication and related driver development degree of difficulty. The API functions of USB communication can add and call USB_Clock_Start(), USB_Init(), USB_Suspend() library functions in build environment of arduino can complete compile. The design of Matlab program mainly completes two functions: graphical user interface and USB host communication and acquired data transfer between the computer and data modem through the USB bus. [5]. Matlab is an innovative development software, which uses a easier to use and understand graphical programming language [6]. The language emphasize the actual process of signal processing, and the acquired data are processed by the powerful computer.

VI. CONCLUSION

This paper provides a data transmission system which will be useful for the people nowadays. The design considerations uses At mega 328 as core controller and RF data modem to transmit the data. The system can reliably and stably achieve wireless data acquisition and transmission. Further more, the new method has some advantages compared with the traditional method, such as low complexity, simple idea, low cost and low power consumption. At the same time, it is a good solution to wireless data transmission.

Acknowledgement

I thank Nehru college of engineering and technology for helping me for the successful completion of this projet. And also I thank all the well wishers and supporters for providing me all the support for this project.

REFERENCES

- 1) Design of Wireless Data Transmission System Based on Si4421 by Zhu Yaolin, Zhang Gaoqiang, Qiao Guina, Zhu Lei School of Electronics and Information Xi'an Polytechnic University China, 978-1-4244-6252-0/11/\$26.00 ©2011 IEEE
- 2) Wireless Serial Communication RF Modem, data sheet by sunroom technologies

- 3) A Wireless Data Acquisition and Transmission System Design, 2009 First International Workshop on Education Technology and Computer Science
- 4) An Experimental Real Time Radio Monitoring System by LUDWIG EVERSON, MEMBER, IEEE, TH0230-3/89/0000-0131 \$1.00 @ 1989 IEEE
- 5) Research of Wireless Data Transmission Based on Embedded Systems, 2009 International Conference on Networking and Digital Society
- 6) Design Wireless Data Transmission System for Small Hydropower Stations Based on nRF24L01, The 1st International Conference on Information Science and Engineering (ICISE2009)
- 7) Wireless Serial Communication RF Modem, data sheet by sunroom technologies
- 8) Atmel 8-bit Microcontroller with 4/8/16/32KBytes In-System Programmable Flash data sheet